



US00D670781S

(12) **United States Design Patent**
Kitchen

(10) **Patent No.:** **US D670,781 S**

(45) **Date of Patent:** **** Nov. 13, 2012**

(54) **TRACK FOR AN AMUSEMENT RIDE**

(76) Inventor: **William J. Kitchen**, Windermere, FL
(US)

(**) Term: **14 Years**

(21) Appl. No.: **29/413,944**

(22) Filed: **Feb. 22, 2012**

Related U.S. Application Data

(62) Division of application No. 29/378,231, filed on Nov. 1, 2010, now Pat. No. Des. 656,213.

(51) **LOC (9) Cl.** **21-03**

(52) **U.S. Cl.** **D21/830**

(58) **Field of Classification Search** D21/811,
D21/814, 818, 821, 828-830; 472/30, 27,
472/43, 45

See application file for complete search history.

(56) **References Cited**

U.S. PATENT DOCUMENTS

489,238	A *	1/1893	Somers	472/45
512,429	A *	1/1894	Wyand	472/45
1,050,567	A *	1/1913	Saunders	472/45
2,082,287	A	6/1937	Hermann	
2,135,230	A	11/1938	Courtney	
2,384,237	A	9/1945	Clark	
2,535,862	A	12/1950	Pewitt	
2,576,477	A	11/1957	Powell	
3,698,710	A	10/1972	Schwarzkopf	
4,988,089	A *	1/1991	Knijpstra	472/45
D327,936	S *	7/1992	House et al.	D21/829
D400,616	S *	11/1998	Gnezdilov	D21/829
6,402,624	B1	6/2002	Larson et al.	
6,994,629	B2	2/2006	Bussink	
7,351,154	B2	4/2008	Müller et al.	
7,686,697	B2	3/2010	Bussink	
D656,213	S *	3/2012	Kitchen	D21/814
2007/0113753	A1	5/2007	Meindl et al.	
2007/0261589	A1	11/2007	Bussink	
2009/0075740	A1	3/2009	Kojro	

FOREIGN PATENT DOCUMENTS

GB	21137	0/1912
GB	22781	0/1911
GB	320758	10/1929
JP	05115618	5/1993
JP	2000-070554	3/2000
JP	2001-104653	4/2001
JP	2002-102544	4/2002
JP	2002-159758	6/2002
JP	2002-273063	9/2002
JP	2002-355446	12/2002
JP	2002-360940	12/2002
JP	2003-024647	1/2003
JP	2003-210853	7/2003
JP	2003-275471	9/2003
JP	2005-328897	12/2005
JP	2007-105353	4/2007
JP	2008-212711	9/2008
JP	2009-148570	7/2009
WO	00/29086	5/2000

* cited by examiner

Primary Examiner — Mitchell Siegel

(74) *Attorney, Agent, or Firm* — Margaret Polson; Oppedahl Patent Law Firm LLC

(57) **CLAIM**

The ornamental design for track for an amusement ride, as shown and described.

DESCRIPTION

FIG. 1 is a front elevational view of the track for an amusement ride, the undisclosed rear being identical; FIG. 2 is a right side elevational view thereof; the undisclosed opposite side being identical; FIG. 3 is a top plan view thereof; FIG. 4 is a bottom plan view thereof; and, FIG. 5 is a front perspective thereof. The broken line showing of support feet and support wires is included for the purpose of illustrating and forms no part of the claimed design.

1 Claim, 5 Drawing Sheets

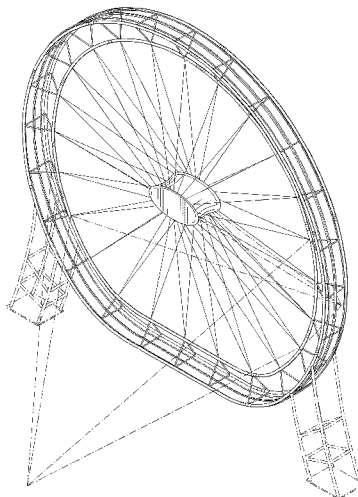

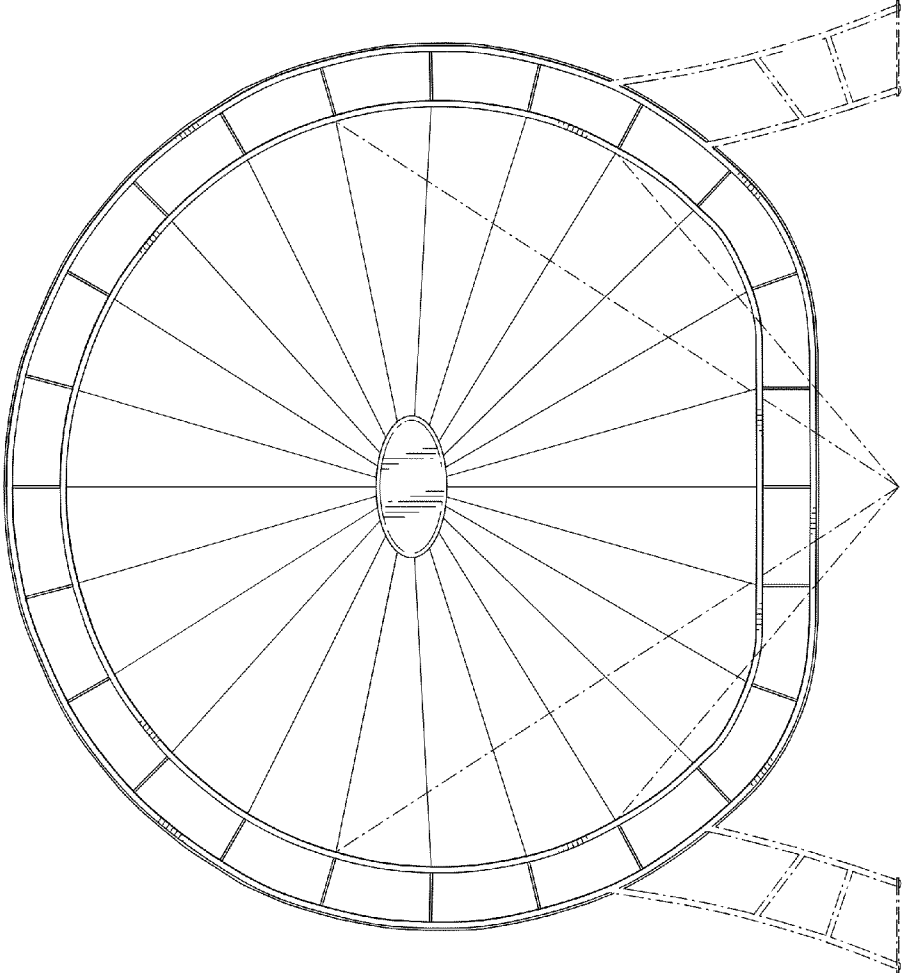

FIG.1

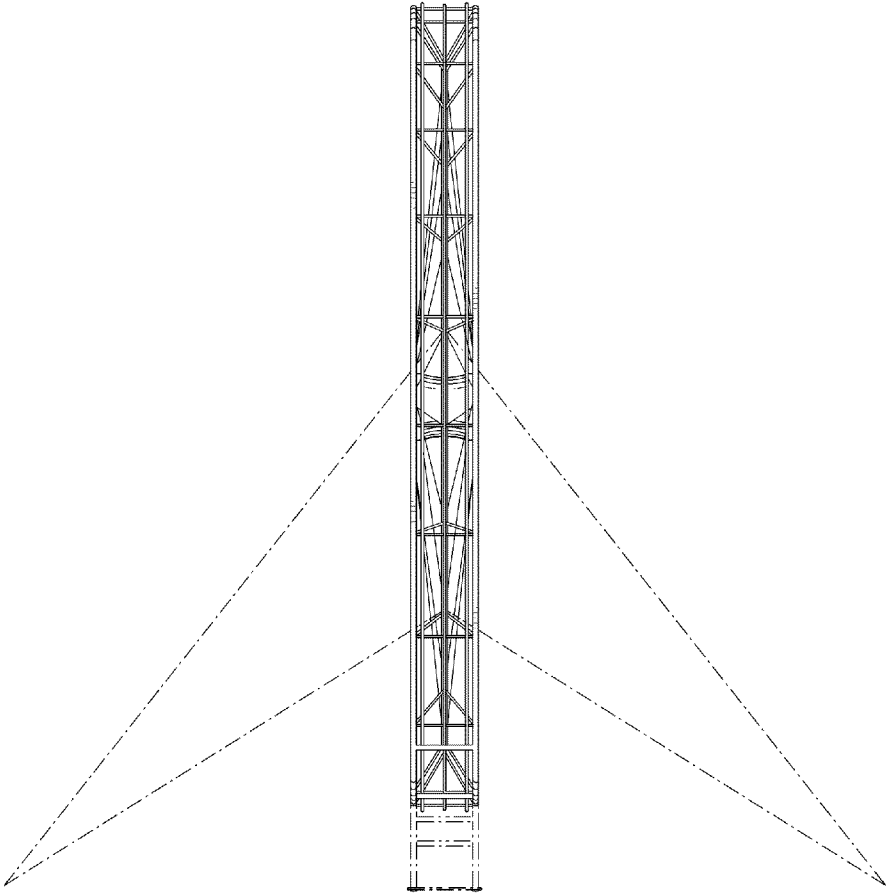

FIG.2

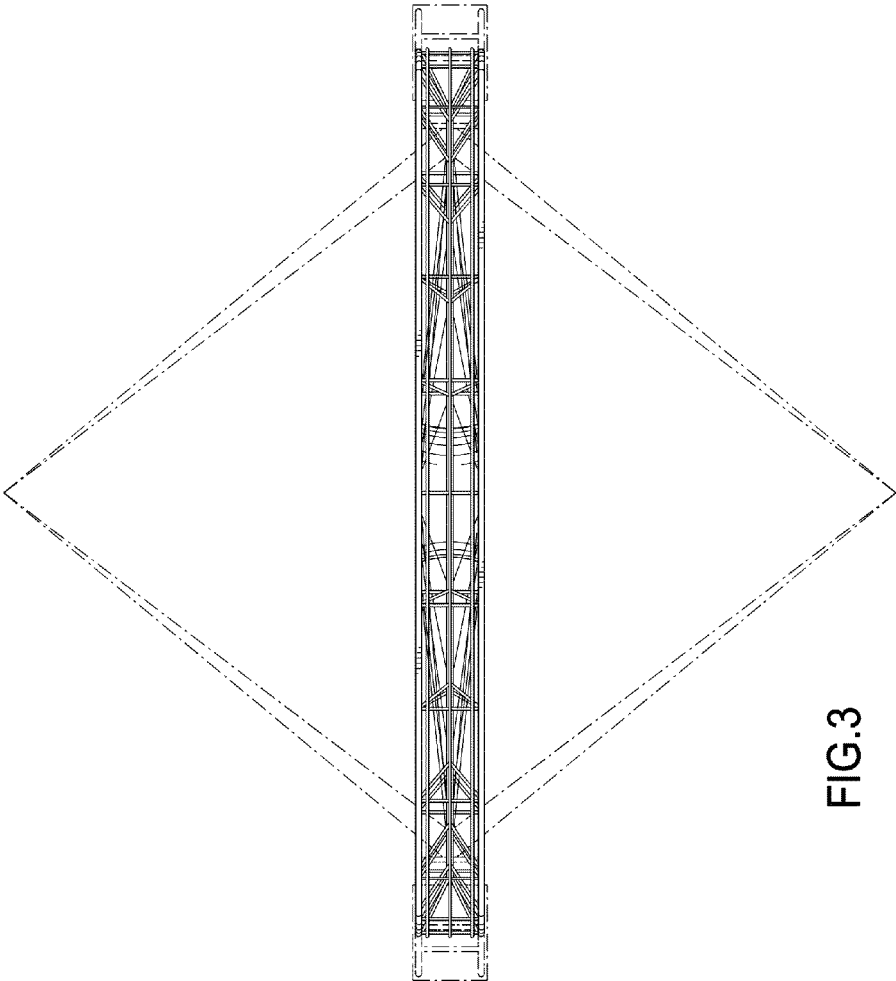

FIG.3

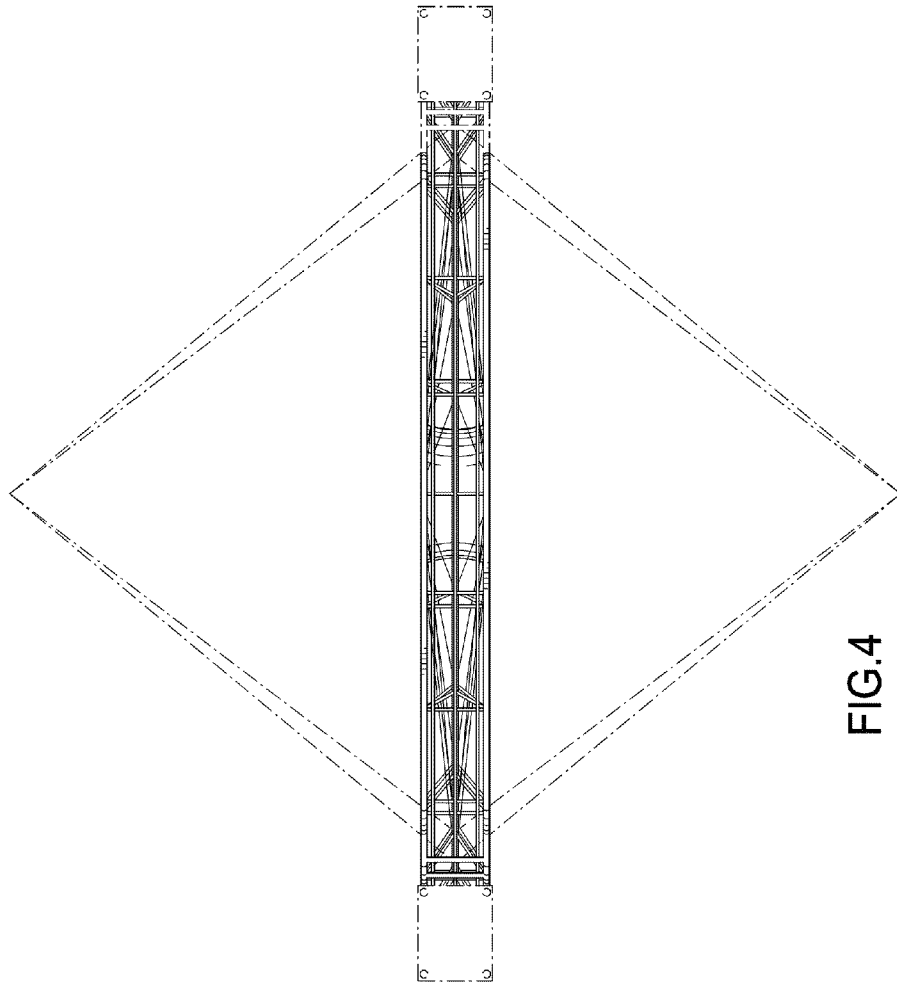

FIG.4

