



INTERNATIONAL APPLICATION PUBLISHED UNDER THE PATENT COOPERATION TREATY (PCT)

<p>(51) International Patent Classification <sup>5</sup> : <b>G01R 33/20</b></p>	<p><b>A1</b></p>	<p>(11) International Publication Number: <b>WO 94/01785</b> (43) International Publication Date: 20 January 1994 (20.01.94)</p>
<p>(21) International Application Number: PCT/US93/04574 (22) International Filing Date: 13 May 1993 (13.05.93) (30) Priority data: 07/912,149 10 July 1992 (10.07.92) US (60) Parent Application or Grant (63) Related by Continuation US 07/912,149 (CIP) Filed on 10 July 1992 (10.07.92) (71) Applicant (for all designated States except US): DOTY SCIENTIFIC, INC. [US/US]; 700 Clemson Road, Columbia, SC 29223-4300 (US).</p>	<p>(72) Inventor; and (75) Inventor/Applicant (for US only) : DOTY, F., David [US/US]; 700 Clemson Road, Columbia, SC 29223-4300 (US). (74) Agents: OPPEDAHL, Carl et al.; Oppedahl &amp; Larson, 1992 Commerce Street, Suite 309, Yorktown Heights, NY 10598-4412 (US). (81) Designated States: AU, CA, JP, US, European patent (AT, BE, CH, DE, DK, ES, FR, GB, GR, IE, IT, LU, MC, NL, PT, SE). <b>Published</b> <i>With international search report. Before the expiration of the time limit for amending the claims and to be republished in the event of the receipt of amendments.</i></p>	

(54) Title: SOLENOIDAL, OCTOPOLAR, TRANSVERSE GRADIENT COILS

(57) Abstract

A structure provides a gradient field useful in magnetic resonance imaging. Axially aligned, solenoidal-like coils (405) are symmetrically distributed around the perimeter of the bore of a superconducting magnet in an MRI system so as to produce transverse gradients in the X and Y directions with exceptionally high efficiency and exceptionally low acoustic noise. Opposed solenoidal endcoils (401) may be added to reduce axial flux leakage by generating an axial quadrupolar field. Radially aligned coils may be positioned near each end of the axial coils to reduce leakage flux by adding a transverse quadrupolar field to form a resulting octopolar field. Typically, the solenoid-like coils have a mean radius of about 15 % of the radius of that of the imaging ellipsoidal region. A thick-walled stainless steel, copper and resin cylinder (701-703) may be used to simplify gradient shielding problems. Silver plated bronze or stainless steel sheet is used as an rf shield (717, 718).

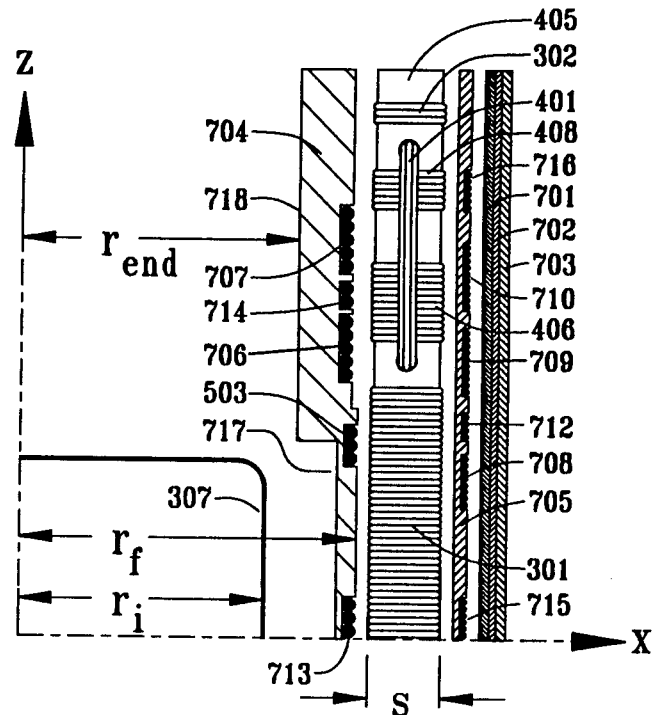

**FOR THE PURPOSES OF INFORMATION ONLY**

Codes used to identify States party to the PCT on the front pages of pamphlets publishing international applications under the PCT.

AT	Austria	FR	France	MR	Mauritania
AU	Australia	GA	Gabon	MW	Malawi
BB	Barbados	GB	United Kingdom	NE	Niger
BE	Belgium	GN	Guinea	NL	Netherlands
BF	Burkina Faso	GR	Greece	NO	Norway
BG	Bulgaria	HU	Hungary	NZ	New Zealand
BJ	Benin	IE	Ireland	PL	Poland
BR	Brazil	IT	Italy	PT	Portugal
BY	Belarus	JP	Japan	RO	Romania
CA	Canada	KP	Democratic People's Republic of Korea	RU	Russian Federation
CF	Central African Republic	KR	Republic of Korea	SD	Sudan
CG	Congo	KZ	Kazakhstan	SE	Sweden
CH	Switzerland	LI	Liechtenstein	SI	Slovenia
CI	Côte d'Ivoire	LK	Sri Lanka	SK	Slovak Republic
CM	Cameroon	LU	Luxembourg	SN	Senegal
CN	China	LV	Latvia	TD	Chad
CS	Czechoslovakia	MC	Monaco	TG	Togo
CZ	Czech Republic	MG	Madagascar	UA	Ukraine
DE	Germany	ML	Mali	US	United States of America
DK	Denmark	MN	Mongolia	UZ	Uzbekistan
ES	Spain			VN	Viet Nam
FI	Finland				

## Description

### Solenoidal, Octopolar, Transverse Gradient Coils

#### Field of the Invention

The field of this invention is electromagnetic coils for the purpose of efficiently generating transverse gradients, especially in magnetic resonance imaging (MRI) and other gradient techniques employing a  
5 superconducting magnet.

#### Background of the Invention

A large number of gradient-based MRI techniques have been developed since its independent invention by Paul Lauterbur and Peter Mansfield in 1973, following  
10 the invention of the static technique of Damadian in 1972. Most modern MRI systems utilize a superconducting solenoid to establish a uniform  $B_0$  (or  $B_z$ ) over the imaging volume. This results in the magnetic field being colinear with the path available for sample  
15 access. Coils are then required to produce monotonic (preferably linear) gradients in  $B_z$  with respect to  $x$ ,  $y$ , and  $z$  over the sample region during precisely determined pulse sequences. The transverse gradients  
( $\delta B_z / \delta x$ ,  $\delta B_z / \delta y$ ) in the prior art have generally been  
20 established by symmetrically located sets of saddle coils, similar to those first described by Golay in U.S. Patent No. 3,569,823 or by related planar coils as disclosed by Roemer, U.S. Patent No. 4,926,125 and  
Morich et al., U.S. Patent No. 5,036,282. Maxwell  
25 pairs are universally used to generate the axial gradient, notwithstanding the incorrect usage of the word "toroidal" by Frese and Siebold in U.S. Patent No. 4,468,622. The instant invention achieves order-of-magnitude improvements in several critical parameters  
30 for transverse gradient coils: acoustic noise, DC

gradient efficiency, and high-speed switching efficiency.

The closest prior art to the instant invention, in terms of magnetic field configuration, appears to be the trapezium loops for use with an electromagnet, as disclosed in the article "Magnetic Field Gradient Coils for NMR Imaging" by Bangert and Mansfield in *Journal Physics, E*, 15, 235 (1982). The semi-cylindrical concept depicted by Mansfield in U.S. Patent No. 4,165,479, while having some similar features, is not closely related, as its major field component is orthogonal to  $B_z$ .

The gradient pulses induce eddy currents and vibrations in nearby conducting structures (especially in flimsy shields, in the cryostat, and in light-weight rf coils) which perturb the field homogeneity following the pulses with time and spatial dependencies that are not easily characterized. Active shielding coils, were first publicly disclosed by Mansfield in 2/1986 at approximately the same time that Roemer filed the patent application which resulted in U.S. Patent No. 4,737,716. Prior independent work was underway at Doty Scientific, who shipped the first such commercially available coils in 1/1987. Figure 1 approximately depicts typical shielded Golay coils to generate  $\delta B_z/\delta x$  in the sample in the vicinity of the origin. A similar set of concentric coils, rotated  $90^\circ$ , is used to generate  $\delta B_z/\delta y$ . Figure 2 shows second-order shielding of the Maxwell pair, or anti-Helmholtz coils, as used to generate linear  $\delta B_z/\delta z$  near the origin. Gradient coils **201, 202** at mean location  $z \approx \pm r_f$  have about 2.5 times the amp-turns of shield coils **203, 204** when  $s \approx 0.3r_f$ . Axial shield coils **205, 206** have about one-tenth the amp-turns of the gradient coils. Gradient linearity of  $\pm 20\%$  is achieved over a sphere of radius  $0.7r_f$ , and leakage flux through a cylinder of radius  $1.4r_f$  is

reduced by a order of magnitude compared to the unshielded case. Higher-order shielding achieves another order-of-magnitude reduction in leakage, but shielding techniques have never fully measured up to  
5 original expectations because of motion-related artifacts, especially ghosting in the phase-encoding direction and battle-zone levels of acoustic noise.

Recovery time is often found to increase quadratically with pulse amplitude, indicating it is related  
10 more to motion than to eddy currents. It is in fact arguable that eddy currents per se are no longer a significant problem with typical shielded coils and optimized multi-exponential high-pass compensation that includes first-order cross terms as described by Van  
15 Vaals and Bergman, but rather the vibrations produced by the eddy currents in passive shields are the cause of residual image artifacts, as the time constants of the high-order eddy currents in passive shields are generally much less than the mechanical vibration time  
20 constants. Kondo et al. in U.S. Patent No. 5,055,789 disclose a partial solution to the image artifact problem.

The gradient coil design problem is fundamentally limited by the conflicting requirements of fast res-  
25 ponde and reasonable field linearity (spatially constant gradients) over the sample volume. The major technical problems center around the following:

(1) limited available space because of economic considerations, (2) motion-induced artifacts arising  
30 from the finite stiffness and mass of the coil support structure, (3) practicable coil winding (or etching) techniques, (4) acoustic noise abatement, and (5) heat dissipation.

The conflicting technical requirements may be  
35 partially addressed by means of local planar gradient coils with highly non-linear response, as disclosed by

Roemer, U.S. Patent No. 4,926,125. By adding distortion correction algorithms to the image processing, it is possible to utilize gradients with  $\pm 40\%$  to  $\pm 60\%$  non-linearity on one axis in applications where high  
5 spatial resolution is required only over a small portion of the image.

The following parameters generally need to be specified for gradient coil systems: gradient coefficient  $\alpha$  (T/Am) (sometimes called gradient efficiency in  
10 the prior art), imaging ellipsoid radius  $r_i$  (m) and axial length  $h_i$  for a specified linearity, inductance  $L$  (H), resistance  $R_E$  ( $\Omega$ ), maximum continuous power dissipation  $P$  (W), maximum pulse current  $I_p$  (A) in a specified  $B_0$ , recovery time  $T_D$  (s) for a specified pulse, and  
15 acoustic noise for a specified pulse sequence in a specified field.

For the fastest imaging techniques, Echo Planar Imaging (EPI) and related techniques, the most important parameters are acoustic noise, recovery time, and  
20 gradient power. EPI can produce complete 2-dimensional images in 30 ms and repeat the process several times per second, compared to minimum imaging times of several minutes for conventional spin-echo techniques. In addition to the enormous prospects for increased  
25 patient throughput in MRI, EPI allows realtime monitoring of heart valve function and even realtime analysis of brain response to visual and auditory stimuli.

Although EPI was first described 15 years ago, it  
30 has seldom been used because prior art gradient coils (a) may require megawatts of gradient driver power on the frequency-encoding axis, (b) generate sound pressure levels that are painful and damaging to the patient's hearing, (c) produce motion-related artifacts  
35 that cannot be fully removed even with the most sophisticated image post-processing, and (d) require

high power audio amplifiers costing up to several million dollars. A recent experimental demonstration at 0.5 T required nearly half a megawatt (at 10% duty cycle) at one kHz, and others have proposed the use of  
5 2 MW at 5 kHz, 1.5 T, and 50% duty cycle for slice-interleaved techniques. The above problems may be partially addressed using a tuned transverse gradient with sinusoidal (monochromatic) current; but the conventional gradient coil has very low electrical Q;  
10 and there are penalties in SNR (signal to noise ratio) and heat dissipation. Also, computational analysis becomes more complex, but that objection is trivial.

While the Maxwell z-gradient is considerably more efficient than the Golay transverse gradient, the  
15 frequency-encoding gradient must be in the plane of the image, which often must be transverse for medical reasons. Hence, order-of-magnitude improvements are needed in transverse gradients.

The image artifact problem can begin to be appreciated by noting that while the frequency-encoding  
20 gradient may be driven with a 500 kW trapezoidal waveform, the phase-encoding gradient is being driven with short "blips" of several kilowatts at very low duty cycle, and the slice-selection axis is nulled. It is  
25 quite easy for non-linear, vibration-dependent couplings between the frequency-encoding axis and the other axes to destroy the required degree of orthogonality between the axes and produce phase-related artifacts. Moreover, cylindrical asymmetries in rf and  
30 gradient shields can make the orthogonality frequency and amplitude dependent.

The availability of better image processing and distortion correction techniques suggests that the linearity standard be increased to  $\pm 20\%$ , compared to  
35 the more typical  $\pm 10\%$  value for prior art whole-body systems. (Linearity in prior art MR microscopy is

typically  $\pm 4\%$  or better because the rf coils require a relatively large exterior dead space, which necessarily makes gradient linearity very good over the small sample region.) Increasing the non-linearity allowance  
5 from  $\pm 10\%$  to  $\pm 20\%$  increases the imaging volume by typically 50%. It is still important that the field be monotonic, but the method of Schenck et al. in U.S. Patent No. 4,646,024 results in relatively poor switching efficiency, intolerable acoustic noise, and unman-  
10 ageable motion-related artifacts.

Designing for large gradient non-linearity with very fast switching capability places increased (though inconsequential) computational demands on the image processing and may result in some increased variation  
15 in SNR over the final image. However, the enormous bandwidth (several MHz) of high-resolution EPI (and other more advanced techniques) can reduce the imaging time by two or three orders of magnitude without placing unrealistic demands on modern computers since  
20 computational power per cost has increased at the rate of 40% per year for the past seven years and that rate is expected to continue for several more years.

Magnetic energy storage estimates can be enlightening. Assume gradients of 1 T/m over an imaging  
25 sphere of 14-mm radius ( $\pm 20\%$  linearity) for a typical solids microscopy application using a transverse gradient coil of 45-mm diameter. We might then expect maximum gradient fields of about 0.02 T (50% more than the sample's maximum) over a volume of perhaps 60 ml  
30 (6 times the sample volume); hence, 0.01 J. Switching this field in 100  $\mu$ s would require 100 W, assuming relatively low resistive loss, which can easily be achieved. In practice, using conventional shielded gradient coils, the inductive energy ( $I^2L/2$ ) is larger  
35 than suggested by simple energy estimates as above by a factor of twenty to one hundred.



While most of the wasted magnetic energy in Golay coils is external to the patient in MRI, the unusable magnetic energy (the integral of the rms value of  $B_x+B_y$ ) over the patient may be an order of magnitude larger than the usable field (the integral of the rms value of  $\delta B_z/\delta x$  or  $\delta B_z/\delta y$  over the image volume). It is the switching of this enormous non-gradient field from the Golay geometry that causes the sensory stimuli in patients during EPI experiments and limits clinical applications. It is also this non-gradient field that is responsible for virtually all of the eddy currents and vibrations induced in the rf coils, as the desired gradient field is axial and its dipole moment is zero.

Conventional transverse gradient coils have always been designed from the deeply ingrained perspective that a single large coil is more efficient and less costly than a collection of smaller coils. This notion may be true most of the time, but not when it comes to complex field geometries. Maxwell's laws make it impossible to design coil systems that generate single field gradients (they must come at least in pairs) but it is not necessary to have large orthogonal field components.

Some prior gradient coil designs have also suffered under the false notion that there is an inherent advantage with very low inductance coils. Higher inductance (more turns) requires higher voltage, but not higher power (VA) for the same switching time. In fact, reducing inductance below 100  $\mu\text{H}$  is detrimental as lead inductance and transmission line problems then become significant. Coil orthogonality (for isolation) and net force cancellation both dictate that integral numbers of turns be used in all coil sets and coil subsets. Hence, the accuracy of the shielding is limited from this quantization. The more turns, the more precisely the gradients can be shielded. Optimum

number of turns is thus determined largely by the VA characteristics and economics of available power devices, magnetic shielding accuracy requirements, and standard wire insulation practice, making 250 V to 800 V (peak differential voltage for a balanced line) at 10 A to 100 A best for large systems. Optimum inductance is typically 0.2 to 1 mH.

#### Summary of the Invention

10 Axially aligned, solenoidal-like coils are symmetrically distributed around the perimeter of the bore of a superconducting magnet in an MRI system so as to produce transverse gradients in the  $x$  and  $y$  directions with exceptionally high efficiency and exceptionally  
15 low acoustic noise. Opposed solenoidal end-coils may be added to reduce axial flux leakage by generating an axial quadrupolar field. Radially aligned coils may be positioned near each end of the axial coils to reduce leakage flux by adding a transverse quadrupolar field  
20 to form a resulting octopolar field. Alternatively, Golay-type coils may be used for the transverse quadrupolar field with some improvement in efficiency. Typically, the solenoidal-like coils have a mean radius of about 15% of the radius of that of the imaging  
25 ellipsoidal region. The cylindrical rf shield between the imaging ellipsoid and the gradient coils may have smaller radius at the ends than near the center. Radial forces in axial gradient systems are largely canceled by concentric support members between the  
30 gradient and shield coils. A thick-walled stainless steel, copper, and resin cylinder may be used to simplify gradient shielding problems. Silver plated bronze or stainless steel sheet is used as an rf shield.

### Brief Description of the Drawings

The invention will be described with respect to a drawing, of which Figure 1 illustrates the prior-art, shielded, Golay-type, transverse gradient coils.

5 Figure 2 is a longitudinal cross section of the prior-art, shielded, Maxwell-pair axial gradient coils.

Figure 3 discloses a pair of opposed solenoidal octopolar coils in longitudinal cross section with typical lines of flux producing a transverse gradient.

10 Figure 4 depicts a quadrant of solenoidal coils with octopolar field inside a passive gradient shield.

Figure 5 discloses an octopolar transverse gradient coil assembly for a single transverse axis.

15 Figure 6 discloses a shielded axial gradient coil system with concentric support members.

Figure 7 is a longitudinal cross section of a complete x-y-z gradient coil system with central inside radius larger than end inside radius.

Figure 8 is a schematic MRI system representation.

20 Figure 9 discloses a c-coil transverse gradient system.

Figure 10 discloses a U-coil transverse gradient system.

25 Fig. 11 shows an axial end view of the structure of Fig. 5;

Fig. 12 shows an alternative embodiment for a coil assembly; and

Fig. 13 shows an alternate embodiment for a coil assembly having inclined solenoidal windings.

30 Throughout the figures, like elements have been shown where possible with like reference numerals.

### Detailed Description of the Preferred Embodiment

35 Qualitative comparisons of various gradient coil geometries of different sizes are often misleading because of the complex expressions for power,

inductance, resistance, and gradient coefficient and the varying degrees of sensitivity to coil motion. For example, power is often proportional to radius to the fifth power for constant winding thickness and voxel  
 5 size. But power may be linear with radius for constant number of voxels and constant relative winding thickness, depending on the relative significance of  $\gamma G r_i T_2$  and SNR in determining spatial resolution, where  $\gamma$  is the magnetogyric ratio,  $G$  is the magnetic field gradient  
 10 (T/m), and  $T_2$  is the spin-spin relaxation time (s). Thus, it is useful to develop dimensionless figures of merit for comparison of various gradient coil systems of various sizes.

We begin a dimensionless analysis by defining a  
 15 switching figure-of-merit, or switching efficiency,

$$\eta_s = \frac{U_s}{U_T}, \quad (1)$$

where  $U_s$  is the gradient energy over the maximum sample volume of  $\pm 20\%$  field linearity and  $U_T$  is the total gradient energy over all space.  
 20

$$U_s \approx g (\alpha I r_i)^2 \frac{V}{2\mu_0}, \quad (2)$$

where  $g$  is a dimensionless integration factor as implicitly defined in the above equation and is approximately equal to 0.2 for typical ellipsoidal  
 25 sample geometry ( $g=0.33$  for a cube),  $V$  is the maximum imaging volume ( $m^3$ ),  $\mu_0$  is the permeability of free space, and  $\alpha$  is the mean gradient coefficient (T/Am).

$$U_T = I^2 \frac{L}{2} , \quad (3)$$

hence, for convenience, we re-define the switching efficiency as

$$\eta_S = \frac{\alpha^2 r_i^4 h_i}{2\mu_0 L} , \quad (4)$$

5 where  $h_i$  is the axial imaging length. The above efficiency has typical numeric value between 0.001 and 0.008 for shielded Golay coils, or 0.005 to 0.03 for Maxwell pairs and quadrupolar coils for use in magnets with transverse  $B_0$ . This suggests at least an order-  
 10 of-magnitude improvement in switching efficiency should be possible for transverse gradients with novel coil geometries.

Next we define a low frequency (LF) efficiency  $\eta_L$  by comparing the quality of the gradient coil system to  
 15 that of a simple solenoid.

$$\eta_L = \frac{P_0}{P_G} , \quad (5)$$

where  $P_0$  is the power required to generate a peak magnetic field of  $B_G$  in a copper solenoid of radius  $r_i$  and length  $2r_i$  at angular frequency  $\omega_1$  at room tempera-  
 20 ture, and  $P_G$  is the power required to generate a peak gradient of  $B_G$  at radius  $r_i$  using the gradient coils for the same conditions.

It is easily shown from basic principles and definitions (and is experimentally confirmed) that

-12-

$$P_0 \approx \frac{B_G^2 \omega_1 V}{\mu_0 Q_0}, \quad (6)$$

where  $Q_0$  is the ratio of the reactance to the series resistance at frequency  $\omega_1$ . The LF Q at room temperature of a copper solenoid (with full surface coverage) with length equal to its diameter is easily estimated as

$$Q \approx 5 r_i \sqrt{\omega_1} \left[ \frac{S^{0.5}}{m} \right], \quad (7)$$

where we assume the copper thickness to be greater than twice the skin depth  $\delta$  at the test frequency. (This condition is not met in small coils at low frequencies, as  $\delta = 6.5$  mm at 100 Hz.) Hence,

$$P_0 \approx B_G^2 \sqrt{\omega_1} \frac{r_i^2}{\mu_0} \left[ \frac{m}{S^{0.5}} \right], \quad (8)$$

$$P_G = I^2 R_E = B_G^2 \frac{R_E}{\alpha r_i^2} \left[ \frac{m}{S^{0.5}} \right], \quad (9)$$

where the constants in the above equations have units as indicated in brackets so as to maintain SI consistency and arise from the skin depth of copper at room temperature as a function of frequency. We now re-define  $\eta_L$  as the ratio of the above expressions for  $P_0$  and  $P_G$ :

$$\eta_L = \frac{\sqrt{\omega_1} \alpha^2 r_i^4}{\mu_0 R_E} \left[ \frac{m}{S^{0.5}} \right]. \quad (10)$$

At 100 Hz, this evaluated to 0.0004 for a typical prior-art transverse coil designed for  $r_i=42$  mm (the copper thickness was about half of the skin depth) but values below 0.0001 are typical for large planar transverse gradient coils. Typical values for Maxwell-pairs are near 0.002, and there is usually little justification for higher LF efficiency. It would appear that there is room for at least an order-of-magnitude improvement in LF efficiency of transverse gradient coils. A more accurate figure of merit governing efficiency during EPI is the product of  $\eta_s$  and the electrical Q at the switching frequency (e.g., 1600 Hz), but that cannot be determined without knowledge of the winding thicknesses and surface areas, which are rarely given in the published literature.

Coil motion is generally the most troublesome design limitation - perhaps because it is more difficult to construct a generalized figure of merit that satisfactorily accounts for vibration of the gradient coils and of the nearby structure. The governing equations change radically depending on whether most of the energy in the gradient pulse spectrum is below or above the fundamental mechanical mode to which it is strongly coupled.

The saddle coils in conventional Golay-type transverse gradient coils in a uniform external magnetic field develop opposite torques which cause the cylindrical coilform to bow in the plane of the z-axis and the desired gradient.

For very small coil systems, the LF limit is usually applicable --  $\omega_g \ll \omega_b$ , where  $\omega_g$  corresponds to the dominant component in the gradient power spectrum and  $\omega_b$

is the fundamental (symmetric bowing) vibration mode. For a cylindrical coilform supporting conventional transverse gradient coils, the form experiences balanced bowing torques equivalent to a transverse force  $F_B$  at the center (and  $-F_B/2$  at each end) approximately equal to  $n_t I B_0 r_f$ , where  $n_t$  is the total number of turns (4 quadrants) and  $r_f$  is the mean radius of the coilform. The bowing stiffness  $k_b$  (N/m) for elastic (Young's) modulus  $Y$ , wall thickness  $w$  (where  $w \ll r_f$ ), and axial coilform length  $h$  is given approximately by

$$k_b \approx 100 \frac{Y r_f^3 w}{h^3} . \quad (11)$$

The bowing mode  $\omega_b$  of a medium-walled cylindrical coilform, heavily loaded at both ends (the typical case), is approximately as follows:

$$\omega_b \approx 5 \frac{r_f c}{h^2} , \quad (12)$$

$$c = \sqrt{\frac{Y}{\rho}} , \quad (13)$$

where  $\rho$  is the mean wall density and  $c$  is the acoustic velocity. (For very thin walls, surface modes occur at lower frequencies. For very thick walls, the coefficient in equation [12] drops to about 3.)

For an axially aligned solenoidal coil in a uniform external field, the Lorentz forces are radial. The radial stiffness of a thin-walled cylinder is



$$k_r = \frac{2\pi h Y w}{r_f}. \quad (14)$$

Thus, the fundamental radial mode  $\omega_r$  of a thin-walled cylinder is

$$\omega_r \approx \frac{c}{r_f}. \quad (15)$$

5           The mechanical energy  $U_M$  in the LF regime is approximately  $F^2/2k$ . It is independent of the pulse length, and seldom significant, as  $k$  can be made quite large.

10           For the typical case of high-power copper coils epoxied into grooves cut into fiberglass forms, it is difficult to estimate effective  $k$  and  $m$  (or  $Y$  and  $\rho$ ) from detailed moment analysis. The fundamental transverse mode may be less than one-third that calculated for a fiberglass cylinder as the transverse  
15 stiffness can be substantially degraded.

          The radial mode is less affected by the addition of a tightly wound copper winding on a cylindrical form than is the transverse mode. Thus, for the typical case where  $h=4r_f$ , with coil mass several times that of  
20 the form mass, the transverse frequency may be one tenth of the radial frequency. Table I gives some properties of typical materials.

TABLE I Materials Properties			
Materials	Density Mg/m <sup>3</sup>	Modulus GPa	c m/s
5 (a) PEEK	1.3	3.6	1700
(b) G-10	1.5	10	2600
(c) N66-60G	1.7	20	3400
(d) Copper	9.0	130	3700
(e) Macor	2.5	62	5000
10 (f) SS304	8.0	190	5000
(g) E-GF	2.6	72	-
(h) Zirconia	5.7	220	6200
(i) WC	15.6	660	6500
(j) Nextel 440	3.1	220	-
15 (k) Alumina	3.9	380	9900
(l) PAN-50 CF	1.8	380	-

NOTES: (a) Polyetheretherketone; (b) Glass cloth reinforced epoxy; (c) Nylon-6/6, 60% glass fiber; (e) 20 machinable glass, Al-B-Si-K-F-O, Corning Glass Works; (f) stainless steel alloy; (g) standard E-glass fiber; (h) partially stabilized with MgO; (i) typical 1-micron tungsten carbide powder; (j) Al-Si-B-O ceramic fiber, 3M; (k) 99.5%; (l) Thornel PAN carbon fiber.

25 For mid-sized to large systems ( $r_f$  greater than 30 to 300 mm),  $\omega_g$  is more likely to be comparable to  $\omega_b$  or a higher vibration mode, and it is here that problems arise because the mechanical recovery time becomes long compared to the gradient pulse length. A conventional 30 transverse mid-sized gradient coil on a G-10 fiberglass cylindrical coilform with  $r_f=35$  mm,  $h=200$  mm, and  $w=5$  mm would have  $\omega_b/2\pi$  in the range of 600 to 1500 Hz, depending on the amount of copper used - unless a Maxwell pair for the z-gradient has been laid in

circumferential grooves on the same form, in which case this mode could be below 300 Hz.

For  $\omega_g \gg \omega_b$ , the motion during a single square pulse of length  $t_g$  (where  $t_g < 1/\omega_b$ ) can be approximated as a mass under the influence of a constant force since the coilform stiffness is negligible compared to the coil's inertia. The coil acceleration  $a$  during the pulse is  $b_1 n_1 I r_f B_0 / m_c$ , where  $m_c$  is the coil mass per quadrant,  $n_1$  is the number of turns per quadrant, and  $b_1$  is a dimensionless function of the coil and coilform geometry with typical value near 2. At the termination of the pulse, the coil will be rotating with tip velocity  $v = \pm a t_g$ . Its mechanical energy is kinetic ( $mv^2/2$ ). Hence, the mechanical energy per quadrant  $U_M$  from a single short pulse is given by

$$U_M = \frac{(b_1 n_1 I r_f B_0 t_g)^2}{2m_c}, \quad (16)$$

since the effective moving mass (half of the coil mass plus adjacent coilform) is comparable to  $m_c$  for typical Golay coils on fiberglass coilforms.

We define a dimensionless electro-mechanical, high-frequency efficiency factor  $\eta_{mh}$ , which we desire to be small:

$$\eta_{mh} = \frac{U_M}{U_S} = \frac{U_M}{\eta_S U_T}. \quad (17)$$

For the typical case of negligible mutual inductance between quadrants, the above ratio is the same for a single quadrant as for the system, whether series connected or parallel connected.

For shielded Golay coils, with the shield coils at radius  $r_f+s$ , where  $s$  is much less than  $r_f$ , the inductance per quadrant is approximately

$$L \approx 8\mu_0 n^2 s. \quad (18)$$

5 Thus,

$$\eta_{mh} \approx \frac{(r_f B_0 t_g)^2}{2\eta_s \mu_0 S m_c}. \quad (19)$$

Clearly, relative mechanical energy during short pulses is minimized by increasing  $\eta_s$ ,  $s$ , and  $m_c$  for a given  $B_0$  and  $t_g$ . Since  $m_c$  would be expected to increase  
 10 as the third power of  $r_f$ , it might appear that motion-related problems are reduced by increasing  $r_f$ . However,  $t_g$  (if inversely proportional to  $B_G$ ) will generally increase as the second, third, or even fourth power of  $r_f$  in large coils, depending on the severity of  
 15 acoustic noise and the amount of power that can be justified. Thus, electro-mechanical energy in the short-pulse limit typically increases very rapidly with  $r_f$  because the pulse lengths must increase.

While relative high-frequency mechanical energy  
 20 per pulse ( $\eta_{mh}$ ) is minimized by reducing the pulse length, a proportional increase in the strength of the gradient is required; hence, equation [16] shows that  $U_M$  remains unchanged. Moreover, the acoustic spectrum would move into the more troublesome range where the  
 25 response would be similar to that of a conventional loudspeaker. Another severe problem that often arises for the high-frequency condition is that  $\omega_g$  may be close to  $\omega_b$  or to one of the higher mechanical modes. The single pulse analysis is invalid near resonance as the  
 30 initial velocity is no longer zero.

For the earlier mid-sized typical example with  $B_0=2$  T,  $t_g=0.5$  ms,  $s=10$  mm, and  $m_c=0.5$  kg,  $\eta_{mh}$  evaluates to approximately 1.6, which means more energy is going into mechanical motion than into gradient energy in the sample. In this case, however, the short-pulse approximations do not apply, as we are close to resonance. Thus, the actual situation is worse by a factor comparable to the mechanical Q, which has been found to lie between 3 and 20 for typical materials and geometries.

The key to reducing both  $U_M$  and relative mechanical energy is to change from the Golay geometry to the predominately solenoidal geometry of octopolar coils as shown in Figure 3. Each octopolar coil consists of a central solenoidal coil **301**, two opposed solenoidal end coils **302**, **303** adding a quadrupolar field in the z direction but not completely negating the dipolar field of the central solenoid **301**, and two cross coils **304**, **305** adding a transverse quadrupolar field. The magnetic flux for a properly wound pair of octopolar coils is mostly confined to the region between the coils as shown, which clearly produces the desired, monotonic field over a large sample region **306** inside sample coil **307**. The magnetic energy external to the sample region is much less than in unshielded prior art, and the passive gradient shield **308** easily makes residual interactions with the main  $B_0$  magnet **309** negligible. Compared to the prior art, the reduced transverse field components of the octopolar geometry substantially reduces electrical hazard to the patient and asymmetrical eddy current interactions with the rf coil **307**. Before considering field linearity or the gradient magnitude, we look at the most significant prior-art limitations - mechanical energy and acoustic noise.

The most efficiently driven mode in the octopolar solenoid is the radial mode, but the mean solenoid radius  $r_c$  is smaller by a factor of 4 to 15 than the Golay  $r_f$  for similar imaging radius  $r_i$ . Hence the resonant frequency is 10 to 100 times higher than the dominant mode for Golay-type coils. Gradient frequencies may be increased by the same factor before getting into the troublesome regime of equations [16] and [19]. The constant  $b_1$  in equation [16] is increased to approximately  $\pi$  for a solenoid, and the coefficient in equation [18] is significantly reduced, but this is balanced by a similar increase in  $\eta_s$ . However, it is now usually possible to stay below resonance, where motion problems are easily eliminated by increasing the stiffness.

The small diameter of the solenoid makes it possible to select coilform materials that would be prohibitively expensive to manufacture at the dimensions required for a Golay coil, where fiberglass forms and ceramic cement encapsulation are used. The radial mode of the solenoid is maximized by choosing a material for its coilform with high  $Y$ , such as alumina, mullite, borosilicate glass, a machinable glass such as Macor, or plastics highly loaded with high-modulus fibers of ceramic, carbon, or glass.

The radial force in a solenoid is simply  $2\pi r_c n I B_0$  and the inductance of a long solenoid is  $\mu_0 n^2 \pi r_c^2 / h$ . Hence, from equation [14] and the above, the mechanical energy,  $F^2/2k$ ,  $U_M$  is

$$U_M = \frac{r_c L I^2 B_0^2}{\mu_0 Y W} . \quad (20)$$

We may define a low-frequency electro-mechanical efficiency factor  $\eta_{ml}$  in the same manner as equation [17] and show that it is

$$\eta_{ml} = \frac{2r_c B_0^2}{\eta_s \mu_0 Y W} \quad (21)$$

for the LF solenoid, which has typical value between 0.0001 and 0.01 for coils suitable for whole-body MRI on high-modulus forms at high fields.

5           The cross coils 304, 305 will also weakly excite a transverse vibration mode, which will be resonant at a much lower frequency. Since the pulse length would often be short compared to the period of this transverse mode, it may be beneficial to select a coilform  
10 material that has high density, such as zirconia or a composite loaded with a dense compound such as tungsten carbide (WC) or zirconia fibers. Fortunately, this transverse mode is driven much less efficiently (by about two orders of magnitude) than is the Golay  $\omega_b$  for  
15 the following reasons: (a) typically only 20% of the total turns are transverse; (b) the mean axial dimension of the cross coils is about half that of Golay coils, which reduces the torque correspondingly; (c) the switching efficiency  $\eta_s$  is increased by about a  
20 factor of four; (d) the solenoidal coilform can easily be made quite stiff and massive.

Equation [21] is also approximately correct for mechanical evaluation of Maxwell pairs used for the z-gradient. However, compared to the octopolar coils,  
25 the z-gradient coil radius will be larger by a factor of four to fifteen, the relative wall thickness may be one tenth as large,  $\eta_s$  may be larger by a factor of two, and Y may be smaller by a factor of 2 to 40 for manufacturing reasons. Thus, the z-gradient may have  
30 two orders of magnitude larger acoustic problems than the transverse gradients - a reversal from the prior art. Fortunately, the z-gradient is normally used only

where the frequency components are very low, as in slice selection or Gradient Enhanced Spectroscopy (GES). An exception has been Pulsed Field Gradient (PFG) diffusion measurement, which may now be performed  
5 using a transverse octopolar gradient rather than the z-gradient for minimum motion-related artifacts.

Referencing Figures 3 and 4, we begin the magnetic analysis by considering a single, azimuthal quadrant of identical octopolar coils, as depicted in Figure 4,  
10 disposed adjacently in a sector with central inside radius  $r_f=1.3r_i$ , outside radius  $r_f+s=1.6r_i$ , with a passive cylindrical shield 308 at radius  $r_f+s+\epsilon$  where  $\epsilon$  is small compared to  $s$ . The relative dimensions selected are convenient for six or eight parallel octopolar coils  
15 per quadrant, depending on the shape of the cross section of the central solenoid 301. Instead of winding individual cross coils 304, 305 on each solenoidal coilform, transverse saddle coils 401, 402 may be threaded through the transverse holes 403, 404 in the  
20 solenoidal coilform 405 to generate the transverse quadrupolar field with some improvement in LF efficiency but with no significant effect on other parameters. Transverse flux leakage may be reduced by extending the central solenoid 301 into the transverse  
25 coil region 406, 407. Transverse and axial flux leakage may be reduced by extending the end coils 302, 303 into the transverse coil region 408, 409. The turns density per unit length near the center of the central solenoid will typically be about 80% of the turns density near the end coils 302, 303 for improved field  
30 linearity over a longer sample region.

The total number of turns in the end coils 302, 303 plus their extensions into the transverse region 408, 409 will typically be about one tenth of the total  
35 turns per octopolar coil and is selected to minimize axial leakage flux. The number of turns in the cross



coils 304, 305 or in the transverse saddle coils 401, 402, whichever are used, is typically about one fifth of the total number of turns and is selected primarily to minimize transverse leakage flux for the system in the absence of the passive shield.

The series inductance  $L_1$  of the quadrant of octopolar coils is approximately

$$L_1 \approx \frac{\mu_0 n_1^2 r_i s}{h_i}, \quad (22)$$

where  $n_1$  is the number of turns on each octopolar coil including the cross coils or Golay coils, and we have assumed  $h_i = 1.5r_i$  and  $s = 0.3r_i$  in omitted second order terms.

Most of the turns are linked by approximately equal flux,  $\phi_1/n_c$ , where  $\phi_1$  is the total flux from the quadrant through the  $z=0$  plane. With the coils all wired in series,

$$\phi_1 \approx \frac{L_1 I_1}{n_1}, \quad (23)$$

where  $I_1$  is the series current. For a parallel arrangement, the inductance is decreased by  $n_c^2$  and the current is increased by  $n_c$ , requiring this factor to be added to equation [23].

The average value of the  $z$ -component of the magnetic field from one quadrant of coils in the  $x$ - $y$  plane at  $z=0$ ,  $\langle B_{z1}(0) \rangle$ , is easily estimated.

$$\langle B_{z1}(0) \rangle \approx \frac{\phi_1}{A_0}, \quad (24)$$

$$A_0 \approx 2\pi r_i^2. \quad (25)$$

The radial distance  $\epsilon$  between the magnetic shield and the coils should be small compared to  $s$ , or leakage flux is increased and  $B_{z1}$  is decreased slightly, particularly if the number of turns in the transverse coils is not chosen to give optimum first-order shielding.

A more sophisticated approach to calculating the magnetic field, such as numerical integration of the Biot-Savart law, is required to determine  $B_{z1}$  as a function of  $x$ . However, a reasonable estimate of its value near the x-y plane at  $x=r_i$  is twice the average value, and its value at  $x=-r_i$  should be about 0.2 times the average value. (The field inside the central solenoids 301 is approximately 10 times that of equation [24].)

Figure 5 discloses the transverse gradient coil system of the instant invention, which includes two opposing quadrants 501, 502 of identical octopolar coils with support structure. The coils are energized so that the average value of the axial component of the magnetic field along the central axis is zero; the average value over the central transverse plane is also zero; the dipole moment of the total magnetic field produced by the coil system is zero; the highly localized fields result in a much smaller quadrupole moment than for Golay coils of similar size; and there are substantial octopole and higher multipole moments.

Eddy currents are induced in the passive cylindrical gradient shield 308 such that the gradient field is confined to the central region when the shield thickness is greater than the skin depth  $\delta$ . The relatively low-level eddy currents induced by the

octopolar coils do not present major problems if the shield rigidity and mass sufficiently limit coupling to acoustic resonances. It is primarily the acoustic modes, rather than the directly induced eddy currents, that have time constants long enough to cause image artifacts that cannot be addressed by pulse shaping. The main exception to this rule is the zero-order  $B_z$  or solenoidal component induced by imperfections in the gradients, which has a decay time constant on the order of  $r_f t_g^{0.5}$  [ $s^{0.5}/m$ ] for thick-walled copper cylinders. But this low-level homogeneous shift is easily nulled with a low-power zero-order (quasi-Helmholtz)  $B_z$  coil **503**, **504** of radius less than that of the gradient shield **308** but larger than that of the internal rf shield **505**.

The energy stored in the acoustic resonances in a strong external magnetic field is responsible for the persistence of the complex eddy currents via microphonic interactions. The eddy current time constant may be decreased by using a high-resistivity alloy for the shield such as austenitic (non-magnetic, 300-series) stainless steels (about 20% Cr, 10% Ni) or by resistive damping as described later. The acoustic time constant is decreased by using a shield with high velocity of sound, high stiffness, and high mechanical loss factor. Improved shielding may be obtained by including a copper or aluminum cylinder, as the skin depth in alloy AISI 304 (UNS S30400) at 20 Hz is about 100 mm while the skin depth in copper is only 15 mm. A copper cylinder **410**, with 3 to 30 mm wall thickness, a stainless steel cylinder **412**, of 2 to 20 mm wall, and a composite resin cylinder **411** therebetween, with resin cylinder thickness less than one half of the total wall thickness, provides a good balance of high stiffness, high conductivity, low permeability, high acoustic damping, and low cost. Performance is a little better

with the copper or aluminum on the inside, but either way provides an effective, passive shield.

The eddy current energy of the instant invention is an order of magnitude lower than that of the unshielded prior art, which greatly reduces the gradient power demands imposed by multi-exponential eddy current compensation techniques. Additional active shielding, beyond optimization of the end coils 302, 303 and transverse coils 401, 402, is not necessary.

The difference between the  $B_z$  values at  $+x$  and  $0$ , according to the previous estimate, is about twice the average value of equation [24]. With all the coils electrically wired in series, the total inductance  $L_T$  is about  $2L_1$  and the total current  $I_T$  is  $I_1$ . The gradient coefficient  $\alpha$  is easily estimated.

$$\delta B = \frac{\beta L_T I_T}{n_i r_i^2}, \quad (26)$$

$$\alpha = \frac{\delta B}{r_i l} = \frac{\beta L_T}{n_i r_i^3}, \quad (27)$$

Our estimate of the field slope implies that  $\beta \approx (2-.2)/4\pi \approx 0.14$ . (Factors of  $n_c$  are required to make equations [22] through [28] valid for parallel arrangements.) Substituting into equation [4] gives

$$\alpha = 2 \frac{\beta \mu_0 n_1 s}{h_i r_i^2}, \quad (28)$$

$$\eta_s = \frac{\beta^2 L_T}{\mu_0 n_1^2 r_i}, \quad (29)$$

$$\eta_s \approx 2 \frac{\beta^2 s}{h} \approx 0.005. \quad (30)$$

Equations [29] and [30] are dimensionless and valid for either series or parallel arrangements. The switching efficiency is clearly independent of  $n_1$  and  $n_C$ , and it is two to five times larger than for shielded Golay-type coils of comparable  $s/h$ .

Another approach to understanding the reason behind the higher switching efficiency of the octopolar coil compared to the Golay coil is to note that only 5% to 15% of the total conductor length is parallel to  $B_z$ . By contrast, about 40% of the conductor length in the Golay coils is parallel to  $B_z$  with totally useless magnetic field. This has not been perceived to be a problem in the prior art because no forces are generated by those conductors parallel to the external field. However, the parallel conductors not only generate harmful field components in the sample and in the rf coils, they are responsible for torques and hence the acoustic problems. Increasing  $s$  and reducing  $h$  in equation [30] increases the switching efficiency but the percentage of conductor length parallel to  $B_z$  increases. The percentage of conductor length substantially parallel to  $B_z$  should be kept below 20% for satisfactory control of transverse fields and acoustic problems. Decreasing  $h$  has the advantage of limiting the field of view and thus reducing the biological hazards from large switching fields.

It should be noted that decreasing the axial field of view by 30% would seldom be a disadvantage, as the

50-ms snapshots possible with EPI would permit the patient to be smoothly conveyed through the imaging zone with little difficulty in treating motion-related artifacts. Proper signal averaging and registration of successive images could readily be achieved.

As the prior art has often been concerned with reducing inductance, we note that the octopolar coils can achieve two orders-of-magnitude lower inductance than Golay-type coils before shielding problems become significant. The total number of turns can be as small as 40 per octopolar coil without excessive flux leakage. The minimum inductance is thus about  $2\mu_0 r_i$ , or under 1  $\mu\text{H}$  for a whole-body parallel octopolar coil system, but the performance per cost of the driver is usually best for 0.2 to 1 mH.

Orthogonality between the three axes should be within 0.01% for EPI. Achieving this degree of orthogonality directly is beyond reasonable manufacturing tolerances, but an external variable coupling (cross-term) circuit at the input of the gradient drivers can be used to null residual magnetic couplings. Maintaining magnetic orthogonality over a typical range of 5 Hz to 5 kHz requires a high degree of precision in the symmetry of the passive gradient shield, the internal rf shield, and the rf coil. Electric field interactions between the axes can easily be made smaller than 0.05% by using balanced coil drivers with low inductance gradient systems (below 1 mH). Winding each quadrant in a series-parallel fashion that leaves the low-voltage points at the edges of the quadrants and the high-voltage points at the centers of the quadrants makes it easy to achieve another order of magnitude reduction in electric field coupling. A typical winding would be 100 to 200 turns per octopolar coil, with half of the octopolar coils per quadrant connected in series and paralleled with the other half.

As can be appreciated by one experienced in the manufacture of Golay coilforms and the winding of Golay coils, the solenoidal octopolar coils are much easier to produce, especially with the high degree of accuracy necessary for precise shielding, axis orthogonality, and low homogeneous shift.

The DC resistance of the series-connected octopolar gradient system is easily shown to be

$$R_E \approx 15 \frac{n_1^2 \rho r_i}{c_i h_i}, \quad (31)$$

where  $\rho$  is the conductivity of the wire and  $c_i$  is the conductor thickness in the coils, for  $c_i$  less than the skin depth. Substituting equations [28] and [31] into equation [10] gives the following low frequency efficiency:

$$\eta_L \approx \frac{\beta^2 \sqrt{\omega \mu_0} c_i s^2}{5 h_i r_i \rho}. \quad (32)$$

At 100 Hz, the above expression simplifies to approximately  $0.3 c_i / r_i$  for the previous conditions. For  $c_i = 6$  mm and  $r_i = 300$  mm, this evaluates to 0.005 and is an order of magnitude larger than for typical prior-art, whole-body MRI transverse gradients. The figure of merit governing power dissipation during EPI is  $\eta_s Q$ . For the above solenoidal octopolar coil geometry,

$$Q \approx 0.25 \frac{s}{\delta}, \quad (33)$$

where the skin depth  $\delta$  is assumed to be small compared to  $c_i$ , and other losses are small. For the previous example, the  $Q$  is about 15 at 1600 Hz since  $\delta = 1.6$  mm.

The coefficient in equation [33] varies between 0.1 and 0.4 for shielded Golay coils, depending primarily on the conductor surface area and the degree of linearization.

5           Another qualitative method of evaluating coil shielding problems is to measure the change in inductance when a passive shield is added. For the unshielded Golay coils, a passive shield with inner radius  $1.3r_f$  typically reduces the inductance by 25%.  
10 For the shielded Golay coils, a passive shield at radial distance  $\epsilon$  from the shield coil, where  $\epsilon=0.03r_i$ , may reduce the inductance by under 0.5% for high-inductance coils, but several percent is more typical for low-inductance coils. For the octopolar coils  
15 without additional shielding coils, the passive shield at  $\epsilon=0.03r_i$  reduces the inductance by several percent. The addition of low-power Golay shielding coils can reduce the effect of the passive shield on inductance change by another order of magnitude.

20           Finally, we note that linearity over the sphere of radius  $r_i$  for the conditions previously assumed is easily better than  $\pm 30\%$ . With proper control of winding densities, especially in the solenoidal coils extending into the cross coil regions, linearity can be  
25 better than  $\pm 20\%$ . Where space permits, increasing  $s/r_f$  improves linearity as well as efficiencies. Optimized winding densities that balance efficiencies, flux shielding, and linearity may be determined by prior-art iterative techniques using the above equations and  
30 standard numerical integration of the Biot-Savart law.

Figure 6 discloses a shielded axial gradient coil system with concentric support members 601. It is important that the z-gradient coils 602 and z-gradient shield coils 603 be wound on coilforms of high-modulus  
35 materials and rigidly joined through the concentric support members 601 to minimize their motion-related



artifacts and acoustic noise. One of the stiffest thermoplastics readily available is nylon 6/6 reinforced with 60% long glass fiber. Further increase in modulus may be achieved by using a high-strength  
5 alumina-silica-boria ceramic fiber such as 3M's Nextel 480, or zirconia fibers, or alumina fibers instead of glass fibers. The low shear strength of such fibers results in low impact strength, which may facilitate machining. Improved impact strength can be achieved by  
10 using a thermoset resin such as polyester or epoxy with a room-temperature cure process allowing high-modulus carbon fibers to be substituted for a fraction of the ceramic fibers. Carbon fiber content must be kept below 15% or electrical conductivity becomes large  
15 enough to cause excessive eddy current losses. Low-temperature cures are required because of the differential thermal expansion between carbon and ceramic fibers which places the ceramic fibers under tensile stress upon cooling. A preferred composite would  
20 include at least 5% carbon fibers and at least 25% ceramic fibers by mass.

For best results, the wires should be securely bonded to the forms with epoxy containing at least 5% carbon fiber to improve both thermal conductivity and  
25 modulus. At least 10% other non-conductive, high-modulus fiber having elastic modulus greater than 60 GPa, such as ceramic fiber or glass fiber, is beneficial for further increase in modulus.

Figure 7 discloses a quadrant of an axial cross  
30 section of the typical x-y-z gradient system of the instant invention, which is symmetric with respect to a 180° rotation about the z-axis and symmetric with respect to a reflection through the x-y plane. The solenoidal coilforms 405 function as concentric support  
35 members and support the central solenoids 301 and transverse saddle coils 401. Z-gradient motion is

reduced by bonding the outside of the z-gradient coil-  
form 704 to the inside of each of octopolar coils 405  
and bonding the inside of the z-shielding coilform 705  
to the outside of each of the octopolar coils 405. The  
5 radial forces from the axial gradient coils 706, 707  
are opposite those of the axial shielding coils 708,  
709, 710 and coupled through the highly rigid sole-  
noidal coilforms. As a result, only the residual net  
force, which is about half of the radial force of the  
10 gradient coils, produces significant motion.

The external passive gradient shield 701, 702,  
703, corresponding to shield 308 substantially elimi-  
nates eddy current effects (cryogen boiling and field  
distortions) in the magnet. It includes copper cylin-  
15 der 410, resin cylinder 702, and stainless steel  
cylinder 703, corresponding to the above mentioned 410,  
411, and 412.

A low-power quasi-Helmholtz zero-order shim coil  
503 may be added for real-time cancellation of the  
20 minute solenoidal eddy currents caused by imperfections  
in the gradients. Placing this  $B_0$  correction coil  
inside the passive gradient shield 308 is far more  
effective than attempting to adjust the current in the  
main magnet  $B_0$  windings to cancel offsets from eddy  
25 currents, as suggested by Kondo in U.S. Patent No.  
5,055,789, or by using the standard  $B_0$  shim coil pro-  
vided inside the magnet cryostat. A zero-order shield  
coil 712 is added to simplify the time dependence of  
the offset correction. The axial location of the  
30 zero-order shim coil 503 and its symmetric counterpart  
are centered approximately at  $\pm z = 0.55r_f$  to improve  
homogeneity in the presence of the zero-order shield  
coil 712. The x-y-z gradient coils may be used for  
cancellation of first-order gradients from eddy cur-  
35 rents by pulse shaping as described by Van Vaals et al.

Second-order, time-dependent correction to  $B_z$  is also beneficial. An orthogonal  $B_z^2$  shim coil could consist of the second order shim coils 713, 714. Coil 713 is centered about the origin and contains  $I_2$  amp-turns. Coil 714 and its symmetric counterpart could be centered at  $\pm z \approx 1.1r_f$  and each contain  $0.5I_2$  negative amp-turns for minimum dipole moment. Second-order shield coils 715, 716 are added to simplify time dependence. Fine conductors are sufficient for the zero-order and second-order shim and shield coils, as they are required only to generate fields less than 0.01% of  $B_0$ , while the x-y-z gradient fields may exceed 10% of  $B_0$ . Higher-order, time-dependent, shielded shim coils would seldom be beneficial owing to the extremely short time constants of the higher-order eddy current modes.

The inside of the gradient coilform must be lined with an rf noise shield 717, 718, for optimum sensitivity and rf tuning stability. Pure copper or silver foil, about 0.1-mm thick, is sufficient for rf noise shielding above 12 MHz. Eddy current problems, except for zero-order  $B_z$ , are not too significant at this foil thickness, and microphonic problems are controlled by securely bonding the foil to the rigid coilform. An improvement in gradient efficiency at higher switching frequencies and a reduction of eddy currents may be obtained by using a copper alloy foil with high electrical resistivity, such as high-silicon bronze alloy C65500, where  $\rho \approx 250 \text{ n}\Omega\text{m}$ , or type 330 stainless steel, where  $\rho \approx 1000 \text{ n}\Omega\text{m}$ , compared to  $17 \text{ n}\Omega\text{m}$  for copper, but other alloys with resistivity above  $100 \text{ n}\Omega\text{m}$  would also be quite advantageous compared to copper for rf noise shielding and eddy current damping - i.e., the high-resistivity foil is effectively a shunt resistor inductively coupled into the eddy current field. The foil thickness may be increased by the square root of

the increase in resistivity to typically 0.2 to 1-mm for equivalent noise shielding. The rf Q of small MRI surface coils would not be significantly affected by the high-resistivity noise shield, and a 0.01-mm to 5 0.03-mm silver plate on the inside surface of the noise shield is sufficient to maintain high Q in large rf coils. The increased inside diameter of the rf shield in the central region 717 compared to the end region 718 allows maximum rf performance by providing the 10 largest possible volume outside the rf coil 307 for rf flux return (effectively increasing the rf filling factor by reducing the external flux density and hence the integral of  $B_1^2$  over the external volume) while making more space available for support of the axial 15 gradient coils 706, 707.

It is in fact possible to eliminate all saddle coils, cross coils, shim coils, and axial gradient coils and simply utilize the axial solenoids to generate transverse gradients when  $s/h_i$  is large, the 20 passive shield is long, and end coils 302 are used to generate an axial quadrupolar field. The eddy currents then induced in the passive shield produce the desired octopolar field. An even number of solenoidal-like axial coils is required - preferably  $4n$ , where  $n$  is an 25 integer. The solenoid cross sections may be round, trapezoidal, or elliptical. They are positioned such that the distance between the central z-axis and each axial coil axis is greater than the major diameter of the solenoids. Opposed currents are applied to the 30 solenoids to generate a transverse gradient.

Figure 8 is a schematic representation identifying those portions of the MRI system most directly related to the instant invention. The superconducting magnet 309 and cryoshims are fully persistent, requiring no 35 real-time control because the highly localized flux from the actively shielded gradient system 801 in

cooperation with the passive shield 308 effectively eliminates eddy currents in the magnet. The frequency-encoding gradient driver 802 would typically be rated at several hundred kilowatts, DC to 20 kHz, and its  
5 gradient coil may be tuned to 1 to 2 kHz. The other gradient drivers 803, 804 would typically be rated at five kilowatts, but hundreds of kilowatts could be used for greater flexibility. Much less power is required for the optional transverse shield-coil drivers 805,  
10 806 and axial shield driver 807. The real-time offset shim driver 808 and real-time  $z^2$  shim driver 809 would typically be ultra-quiet DC-50 kHz amplifiers rated less than 100 W continuous. A high-resistivity noise shield 810 isolates the tuned rf coil 307 from the  
15 gradient noise and helps damp eddy currents. The nuclei in the sample are magnetized by rf pulses at the mean Larmor frequency from a high-power rf amplifier 811, and the precession signals are amplified by low-noise preamp 812 and processed by the computer 813.

20 Figure 9 discloses a quadrant of a longitudinal cross section of a c-coil embodiment of the instant invention for the generation of transverse gradients. Non-ferromagnetic c-coils 900 rather than solenoids, are symmetrically distributed around the inside perimeter of a passive shield 308 inside the bore of a  
25 superconducting magnet in a fashion similar to that depicted in Figures 4 and 5. The passive shield 308 prevents significant interaction with the magnet, and eddy current effects may be canceled with gradient pulse shaping according to the prior art and time-  
30 dependent zero-order and second-order shim coils as described previously. Partial-toroidal section 902 at each end of a central solenoidal section 901 reduces flux leakage. Performance is substantially better than  
35 prior art transverse gradient coils with respect to

acoustic noise and manufacturability but efficiencies and linearity are inferior.

Figure 10 discloses a quadrant of a longitudinal cross section of a u-coil embodiment of the instant invention for the generation of transverse gradients. U-coils 1000, comprising an axial central solenoidal section 1002 and a transverse section 1001 at each end, are symmetrically distributed around the inside perimeter of a passive shield 308 inside the bore of a superconducting magnet in a fashion similar to that depicted in Figures 4 and 5. Performance is somewhat inferior to that of the octopolar coils of Figure 4 but generally better than that of the c-coils of Figure 9.

Turning now to Fig. 11, there is shown an axial end view of the structure of Fig. 5. As was mentioned above in connection with Fig. 7, the solenoidal coil-forms may be in cross section round, trapezoidal, or elliptical. Fig. 11 shows the trapezoidal configuration, with trapezoidally shaped solenoid coilforms 405 which offers higher gradient coefficient as the ratio of the mean distances from the sample to the outer and inner current elements responsible for the gradient has increased. Also, the space available for external flux has increased, thus reducing the energy in the external field. The cross section is not a true trapezoid, as the edges are radiused and the flats are slightly convex to facilitate coil winding.

As was described above in connection with Fig. 7, one embodiment of the solenoid is to have the transverse coil 401 interleaved with a portion of the central solenoid 301 and interleaved with a portion of the end coil 302. As mentioned above, this interleaving reduces transverse and axial flux leakage. The central solenoid is partitioned into  $2n+1$  parts, and the end coil is partitioned into  $n+1$  parts, where  $n=1$ .

However, those skilled in the art will appreciate that a slightly more complex solenoid configuration would reduce flux leakage still further. Fig. 12 illustrates at (b) such an alternative embodiment for a coil assembly where  $n=2$  for the central solenoid but  $n=1$  for the end coil. At (a) is seen a side view of a coilform 405 such as appears in Fig. 7. As described previously, end coil 302 has been partitioned physically into coils 302 and 408, and central solenoid 301 has been partitioned physically into coils 301 and 406, while transverse coil 401 is interleaved, passing for example between coils 302 and 408, and between coils 301 and 406. At (b) is seen a corresponding side view of the more complex solenoid configuration. End coil 302 has been partitioned physically into coils 302, 408, and central solenoid 301 has been partitioned physically into coils 301, 406a, and 406b. Transverse coil 401 is partitioned into coils 401a and 401b. As shown at (b), transverse coil 401a is interleaved, passing for example between coils 302 and 408, and between coils 301 and 406a. Transverse coil 401b is interleaved, passing for example between coils 408, and between coils 406a and 406b. Thus the central coil is in five parts, and each end coil is in two parts.

Many variants are possible without departing from the basic principle of interleaving. For example, for  $n=2$  for the end coil, coil 408 in the structure at (b) would be divided into two parts, with an upper portion as shown and a lower portion inside coil 401b adjacent to coil 406b. Alternatively, with  $n=3$  for the central solenoid, coil 301 in the structure at (b) would be divided again, with another cross coil 401c.

Still further variants may be found in interleaving with finer structure, for example, where  $n$  has values higher than 2. Flux leakage would be reduced

still further, though with the tradeoff of a more complex structure for the coil.

It will be appreciated that the reflective symmetry requirement for the solenoid entails that  
5 central solenoid 301 is partitioned into an odd number of coils, namely  $2n+1$ .

Figure 13 illustrates an alternative embodiment for a coil assembly in accordance with the invention wherein an octapolar field is obtained without the use  
10 of radially aligned cross coils. The solenoidal-like windings are inclined at pronounced, symmetric angles at opposite ends 1302, 1303 of the central solenoid 1301. Orthogonal fields are produced by the inclined end coils 1304, 1305. These octopolar coils are  
15 distributed around the perimeter of the bore of the superconducting magnet in the manner illustrated in Figures 4 and 5 for octopolar solenoids having radially aligned cross coils.

Although this invention has been described herein  
20 with reference to specific embodiments, it will be recognized that changes and modifications may be made without departing from the spirit of the present invention. All such modifications and changes are intended to be included within the scope of the  
25 following claims.



Claims

- 1 1. A non-ferromagnetic transverse gradient coil  
2 system having a central axis, said system  
3 comprising:  
4 an even number of solenoidal-like central  
5 axial coils having a major diameter wound on rigid  
6 coilforms having axial coil axes parallel to said  
7 central axis and positioned such that the distance  
8 between said central axis and each said axial coil  
9 axis is greater than the major diameter of said  
10 axial coils, the coils arranged in two groups, the  
11 groups substantially symmetrical to each other  
12 with respect to 180° rotation about the central  
13 axis, the coils being substantially symmetrical  
14 with respect to reflection through a plane  
15 perpendicular to said central axis.
- 1 2. The coil system of claim 1 wherein each of said  
2 axial coils further characterized by having turns  
3 density at symmetrical non-central locations  
4 greater than the turns density near its center.
- 1 3. The coil system of claim 1 wherein each of the  
2 groups of coils further comprises a pair of saddle  
3 coils symmetrically disposed one near a first end  
4 of the axial coils and the other near the other  
5 end of the axial coils, said saddle coils having  
6 axes aligned substantially radially from said  
7 central axis.
- 1 4. The coil system of claim 1 in which each axial  
2 coil further comprises end coils coaxial with the  
3 central coil thereof and symmetrically secured  
4 beyond the end of said central coil.

- 1 5. The coil system of claim 1 further comprising a  
2 metallic shield cylinder having electrical conduc-  
3 tivity less than 30 nano-ohm-meters symmetrically  
4 surrounding said coil system.
- 1 6. The coil system of claim 1 in which said rigid  
2 coilforms are made from a nonmetallic material  
3 have elastic modulus greater than 12 GPa and  
4 density greater than 2 g/cm<sup>3</sup>.
- 1 7. The coil system of claim 1 in which said central  
2 coils are further characterized by having windings  
3 inclined with respect to the coil axis.
- 1 8. The coil system of claim 1 in which said rigid  
2 coilforms have substantially trapezoidal cross-  
3 section.
- 1 9. The coil system of claim 1 further comprising a  
2 plurality of cross coils disposed at each end of  
3 said central coils, said cross coils having axes  
4 aligned substantially radially.
- 1 10. The coil system of claim 9 in which said axial  
2 coils generate a transverse gradient field and in  
3 which said saddle coils, when energized, generate  
4 a transverse quadrupolar field such that said  
5 transverse gradient field is increased in said  
6 central region.
- 1 11. The coil system of claim 10 in which said end  
2 coils and said central coils, when energized,  
3 generate a magnetic field with a substantial axial  
4 quadrupolar component.

- 1 12. The coil system of claim 1 in which said rigid  
2 coilforms have substantially round cross-section.
- 1 13. The coil system of claim 1 in which said coilform  
2 made from a material selected from the set  
3 consisting of alumina, silicon nitride, zirconia,  
4 alumina-silica-boria glasses, borosilicate  
5 glasses, machinable glasses, plastic composites  
6 having at least 10% carbon fiber content, plastic  
7 composites having more than 25% ceramic fiber  
8 content, and plastic composites having density  
9 greater than 2.0 g/cm<sup>3</sup>.
- 1 14. An x-y gradient coil system comprising first and  
2 second non-ferromagnetic transverse gradient coil  
3 systems, each transverse gradient coil system  
4 being substantially symmetrical with respect to  
5 180° rotation about a central axis and substan-  
6 tially symmetrical with respect to reflection  
7 through a plane perpendicular to said central  
8 axis, each said transverse gradient coil system  
9 comprising an even number of solenoidal-like  
10 central axial coils having a major diameter wound  
11 on rigid coilforms having axial coil axes parallel  
12 to said central axis and positioned such that the  
13 distance between said central axis and each said  
14 axial coil axis is greater than the major diameter  
15 of said axial coils, each of said axial coils  
16 further characterized by having turns density at  
17 symmetrical non-central locations greater than the  
18 turns density near its center, the central axes of  
19 the transverse gradient coil systems being coinci-  
20 dent, the transverse gradient coil systems being  
21 oriented orthogonally to each other, whereby said  
22 x-y coil system is capable of producing transverse

- 23           gradients in the central axial field in two  
24           orthogonal directions.
- 1    15.   The coil system of claim 14 in which said central  
2           axial coils are substantially round in cross  
3           section.
- 1    16.   The coil system of claim 14 in which said central  
2           axial coils are substantially trapezoidal in cross  
3           section.
- 1    17.   A gradient coil system for use in magnetic  
2           resonance imaging employing a superconducting  
3           magnet to establish a magnetic field  $B_z$ , said coil  
4           system comprising:  
5                current conducting elements disposed to  
6                generate a transverse gradient in  $B_z$ , said  
7                conducting elements arranged such that they are  
8                substantially nonparallel to  $B_z$  over more than 80%  
9                of their total length;  
10               a rigid form to support said conducting  
11               elements; and  
12               said conducting elements further comprising:  
13               a plurality of loops having dipole moment  
14               parallel to  $B_z$ ;  
15               a plurality of loops having dipole moment  
16               perpendicular to  $B_z$ ;  
17               said loops arranged substantially symmetri-  
18               cally with respect to a 180° rotation about the z  
19               axis and substantially symmetrically with respect  
20               to a reflection through a plane perpendicular to  
21               said axis.
- 1    18.   The coil system of claim 17 in which said loops  
2           having dipole moment parallel to  $B_z$  are  
3           substantially round.

- 1 19. The coil system of claim 17 in which said loops  
2 having dipole moment parallel to  $B_z$  are  
3 substantially trapezoidal.
- 1 20. A non-ferromagnetic elongate U-coil for producing  
2 an external localized flux region, said U-coil  
3 comprising:  
4 a central substantially solenoidal coil wound  
5 on a coilform of length  $h_s$  and major diameter  $d_s$   
6 and having a mean first axis of symmetry;  
7 two transverse coils, one disposed at each  
8 end of said central solenoidal coil, having axes  
9 perpendicular to said first axis, and having  
10 outside diameter  $d_T$  and axial length  $h_T$  such that  
11  $h_T$  is less than  $d_s$ .
- 1 21. The U-coil of claim 20 in which each said trans-  
2 verse coil comprises a cross coil, each said cross  
3 coil wound on the coilform.
- 1 22. the U-coil of claim 20 in which each said trans-  
2 verse coil comprises a saddle coil portion, said  
3 saddle coil portion comprising conductors threaded  
4 through transverse holes in the coilform.
- 1 23. The U-coil of claim 20 in which said central  
2 solenoidal coil is substantially round in cross  
3 section.
- 1 24. The U-coil of claim 20 in which said central  
2 solenoidal coil is substantially trapezoidal in  
3 cross section.
- 4 25. The U-coil of claim 20 in which said coilform is  
5 made from a material selected from the set

6 consisting of alumina, silicon nitride, zirconia,  
7 alumina-silica-boria glasses, borosilicate  
8 glasses, machinable glasses, plastic composites  
9 having at least 10% carbon fiber content, plastic  
10 composites having more than 25% ceramic fiber  
11 content, and plastic composites having density  
12 greater than  $2.0 \text{ g/cm}^3$ .

1 26. A gradient coil system comprising a plurality of  
2 U-coils, each U-coil comprising a central substan-  
3 tially solenoidal coil wound on a coilform of  
4 length  $h_s$  and major diameter  $d_s$  and having a mean  
5 first axis of symmetry, and two transverse coils,  
6 one disposed at each end of said central sole-  
7 noidal coil, having axes perpendicular to said  
8 first axis, and having outside diameter  $d_T$  and  
9 axial length  $h_T$  such that  $h_T$  is less than  $d_s$ ,  
10 said U-coils distributed about a central axis  
11 in two groups, the groups disposed substantially  
12 symmetrically with respect to a 180-degree  
13 rotation about said central axis and substantially  
14 symmetrical with respect to a reflection through a  
15 plane perpendicular to said central axis.

1 27. The system of claim 26 in which each said trans-  
2 verse coil comprises a cross coil, each said cross  
3 coil wound on a respective solenoidal coilform.

1 28. The system of claim 26 in which each said trans-  
2 verse coil comprises a saddle coil portion, said  
3 saddle coil portion comprising conductors threaded  
4 through transverse holes in the solenoidal coil-  
5 form; the saddle coil portions together defining  
6 transverse saddle coils threaded through the  
7 transverse holes.

- 1 29. The system of claim 26 in which each said central  
2 solenoidal coil is substantially round in cross  
3 section.
- 1 30. The system of claim 26 in which each said central  
2 solenoidal coil is substantially trapezoidal in  
3 cross section.
- 1 31. A non-ferromagnetic elongate c-coil for producing  
2 an external localized flux region, said c-coil  
3 comprising:  
4 a central substantially solenoidal coil  
5 having an axis, said coil of axial length  $h_s$  and  
6 major diameter  $d_s$  wound on a rigid solenoidal  
7 coilform for which  $h_s$  is greater than  $d_s$ ;  
8 two partial-toroidal coils, each wound on a  
9 rigid partial-toroidal coilform, said partial-  
10 toroidal coils disposed symmetrically in a first  
11 plane at respective ends of said solenoidal coil;  
12 and  
13 a tapered section connecting said partial-  
14 toroidal coilform to said solenoidal coilform,  
15 said tapered section being inclined at a small  
16 acute angle in said first plane with respect to  
17 said axis of said solenoidal coil;  
18 said c-coil further characterized by being  
19 substantially symmetrical with respect to a  
20 reflection through a second plane perpendicular to  
21 the axis of said solenoidal coil.
- 1 32. The c-coil of claim 31 in which said solenoidal  
2 coilform is made from a nonmetallic material with  
3 elastic modulus greater than 12 GPa.

- 1 33. The c-coil of claim 31 in which said central  
2 substantially solenoidal coil is substantially  
3 round in cross section.
- 1 34. The c-coil of claim 31 in which said central  
2 substantially solenoidal coil is substantially  
3 trapezoidal in cross section.
- 1 35. A transverse gradient coil system comprising a  
2 plurality of c-coils, each c-coil comprising:  
3 a central substantially solenoidal coil  
4 having an axis, said coil of axial length  $h_s$  and  
5 major diameter  $d_s$  wound on a rigid solenoidal  
6 coilform for which  $h_s$  is greater than  $d_s$ ;  
7 two partial-toroidal coils, each wound on a  
8 rigid partial-toroidal coilform, said partial-  
9 toroidal coils disposed symmetrically in a first  
10 plane at respective ends of said solenoidal coil;  
11 and  
12 a tapered section connecting said partial-  
13 toroidal coilform to said solenoidal coilform,  
14 said tapered section being inclined at a small  
15 acute angle in said first plane with respect to  
16 said axis of said solenoidal coil;  
17 said c-coil further characterized by being  
18 substantially symmetrical with respect to a  
19 reflection through a second plane perpendicular to  
20 the axis of said solenoidal coil;  
21 said c-coils distributed about a central axis  
22 so as to be geometrically substantially  
23 symmetrical with respect to a  $180^\circ$  rotation about  
24 said central axis and having said second planes  
25 coincident.



- 1 36. The system of claim 35 in which each said central  
2 solenoidal coil is substantially round in cross  
3 section.
- 1 37. The system of claim 35 in which each said central  
2 solenoidal coil is substantially trapezoidal in  
3 cross section.
- 1 38. An x-y gradient coil system comprising first and  
2 second transverse gradient coil systems, each  
3 transverse gradient coil system comprising a plurality  
4 of c-coils, each c-coil comprising:  
5 a central substantially solenoidal coil  
6 having an axis, said coil of axial length  $h_s$  and  
7 major diameter  $d_s$  wound on a rigid solenoidal  
8 coilform for which  $h_s$  is greater than  $d_s$ ;  
9 two partial-toroidal coils, each wound on a  
10 rigid partial-toroidal coilform, said partial-  
11 toroidal coils disposed symmetrically in a first  
12 plane at respective ends of said solenoidal coil;  
13 and  
14 a tapered section connecting said partial-  
15 toroidal coilform to said solenoidal coilform,  
16 said tapered section being inclined at a small  
17 acute angle in said first plane with respect to  
18 said axis of said solenoidal coil;  
19 said c-coil further characterized by being  
20 substantially symmetrical with respect to a  
21 reflection through a second plane perpendicular to  
22 the axis of said solenoidal coil;  
23 said c-coils distributed about a central axis  
24 so as to be geometrically substantially  
25 symmetrical with respect to a  $180^\circ$  rotation about  
26 said central axis and having said second planes  
27 coincident;

28           the first and second transverse gradient coil  
29           systems disposed so that said central axes and  
30           said second planes are coincident, the gradient  
31           coil systems disposed orthogonally to each other,  
32           whereby said x-y coil system produces transverse  
33           gradients in the central axial field in two  
34           orthogonal directions.

1    39.   The system of claim 38 in which each said central  
2           solenoidal coil is substantially round in cross  
3           section.

1    40.   The system of claim 38 in which each said central  
2           solenoidal coil is substantially trapezoidal in  
3           cross section.

1    41.   A passive cylindrical RF shield of the type for  
2           use in magnetic resonance imaging employing a  
3           superconducting magnet to establish a magnetic  
4           field  $B_z$ , said shield comprising:  
5                 a nonmagnetic metal alloy foil having bulk  
6                 resistivity greater than 100 nano-ohm-meters and a  
7                 plating less than 0.03 mm thick on one side of  
8                 said foil, said plating being either copper or  
9                 silver, said foil having thickness between 0.2 mm  
10                and 1 mm, and said shield symmetrical about the z  
11                axis and symmetrical with respect to a reflection  
12                through a plane perpendicular to said axis.

1    42.   An RF shield for a gradient coil system for use in  
2           magnetic resonance imaging employing a  
3           superconducting magnet to establish a magnetic  
4           field  $B_z$ , said coil system comprising a plurality  
5           of current conducting elements disposed to  
6           generate a transverse gradient in  $B_z$ , said element  
7           disposed substantially symmetrically with respect

8 to a 180° rotation about the z axis and  
9 substantially symmetrically with respect to a  
10 reflection through a plane perpendicular to said  
11 axis, said elements disposed at minimum distance  
12  $r_{\min}$  from said axis and maximum distance  $r_{\max}$  from  
13 said axis, said RF shield comprising:  
14 a cylindrical foil with radius larger than  $r_{\min}$   
15 but smaller than  $r_{\max}$  substantially centered within  
16 said system.

1 43. A passive cylindrical gradient shield for use in  
2 magnetic resonance imaging employing a  
3 superconducting magnet to establish a magnetic  
4 field  $B_z$ , said shield symmetrical about the z axis  
5 and symmetrical with respect to a reflection  
6 through a plane perpendicular to said axis;  
7 said shield comprising an inner metallic  
8 cylinder, an outer metallic cylinder, and a resin  
9 cylinder bonded therebetween;  
10 said metallic cylinders having wall thickness  
11 greater than 2 mm and less than 40 mm;  
12 said resin cylinder having wall thickness  
13 less than one half of the total wall thickness of  
14 said shield;  
15 one of said metallic cylinders being an alloy  
16 having electrical resistivity less than 30 nano-  
17 ohm-meters and the other of said metallic  
18 cylinders being an austenitic Cr-Ni-Fe alloy.

1 44. A gradient coil system for use in magnetic  
2 resonance imaging employing a superconducting  
3 magnet to establish a magnetic field  $B_z$ , said  
4 system substantially symmetrical with respect to a  
5 180° rotation about the z axis and substantially  
6 symmetrical with respect to a reflection through a

7 plane perpendicular to said axis; said coil  
8 system comprising:  
9 a gradient assembly comprising:  
10 gradient coils for generating gradients in  $B_z$ ;  
11 and  
12 a rigid form to support said coils;  
13 a conductive passive gradient shield with  
14 diameter greater than the outside diameter of said  
15 gradient assembly;  
16 a conductive RF shield with diameter less  
17 than the inside diameter of said gradient  
18 assembly; and  
19 an axially aligned zero-order  $B_z$  shim coil  
20 with diameter less than that of said passive  
21 shield but greater than that of said RF shield.

1 45. A gradient coil system for use in magnetic  
2 resonance imaging employing a superconducting  
3 magnet to establish a magnetic field  $B_z$ , said  
4 system substantially symmetrical with respect to a  
5  $180^\circ$  rotation about the z axis and substantially  
6 symmetrical with respect to a reflection through a  
7 plane perpendicular to said axis; said coil  
8 system comprising:  
9 a gradient assembly comprising:  
10 gradient coils for generating gradients in  $B_z$ ;  
11 and  
12 a rigid form to support said coils;  
13 a conductive passive gradient shield with  
14 diameter greater than the outside diameter of said  
15 gradient assembly;  
16 a conductive RF shield with diameter less  
17 than the inside diameter of said gradient  
18 assembly; and  
19 an axially aligned second-order shielded  $B_z$   
20 shim coil with diameter less than that of said

21 passive shield but greater than that of said RF  
22 shield.

1 46. A gradient coil system for use in magnetic  
2 resonance imaging employing a superconducting  
3 magnet to establish a magnetic field  $B_z$ , said coil  
4 system comprising:  
5 gradient coils for generating an axial  
6 gradient  $dB_z/dz$  disposed on a first cylinder;  
7 shielding coils disposed on a second cylinder  
8 of radius larger than that of first said cylinder;  
9 and  
10 at least four rigid support members disposed  
11 axially in the radial space between said first and  
12 second cylinders and bonded to said first and  
13 second cylinders to permit rigid transfer of  
14 radial forces.

1 47. A gradient coil system for use in magnetic  
2 resonance imaging employing a superconducting  
3 magnet to establish a magnetic field  $B_z$ , said  
4 elements substantially symmetrical with respect to  
5 a  $180^\circ$  rotation about the z axis and substantially  
6 symmetrical with respect to a reflection through a  
7 plane perpendicular to said axis; said coil  
8 system comprising:  
9 current conducting elements for generating a  
10 transverse gradient in  $B_z$ ;  
11 a rigid form to support said conducting  
12 elements; and  
13 a thermoset resin bonding said conducting  
14 elements to said form;  
15 said resin containing at least 5% carbon  
16 fibers and at least 10% nonconductive fiber by  
17 mass; and

18                   said nonconductive fiber having modulus  
19                   greater than 60 GPa.

1    48.   A non-ferromagnetic elongate coil for producing an  
2           external localized flux region, said coil  
3           comprising:

4                   a central substantially solenoidal coil wound  
5                   on a coilform of length  $h_s$  and major diameter  $d_s$   
6                   and having a mean first axis of symmetry;

7                   two transverse coils, one disposed at each  
8                   end of said central solenoidal coil, having axes  
9                   perpendicular to said first axis, and having  
10                  outside diameter  $d_T$  and axial length  $h_T$  such that  
11                   $h_T$  is less than  $d_s$ ;

12                  a portion of the turns of each of the  
13                  transverse coils interleaved with a portion of the  
14                  turns of the central substantially solenoidal  
15                  coil.

1    49.   The coil of claim 48 in which each said transverse  
2           coil comprises a cross coil, each said cross coil  
3           wound on a respective solenoidal coilform.

1    50.   The coil of claim 48 in which each said transverse  
2           coil comprises a saddle coil portion, said saddle  
3           coil portion comprising conductors threaded  
4           through transverse holes in the solenoidal  
5           coilform.

1    51.   The coil of claim 48 in which said central  
2           solenoidal coil is substantially round in cross  
3           section.

1    52.   The coil of claim 48 in which said central  
2           solenoidal coil is substantially trapezoidal in  
3           cross section.

- 1 53. The coil of claim 48 in which said coilform is  
2 made from a material selected from the set  
3 consisting of alumina, silicon nitride, zirconia,  
4 alumina-silica-boria glasses, borosilicate  
5 glasses, machinable glasses, plastic composites  
6 having at least 10% carbon fiber content, plastic  
7 composites having more than 25% ceramic fiber  
8 content, and plastic composites having density  
9 greater than 2.0 g/cm<sup>3</sup>.
- 1 54. The coil of claim 48 in which the central  
2 substantially solenoidal coil is partitioned into  
3 top, middle, and bottom portions, a first of the  
4 transverse coils is interleaved with the top  
5 portion, and the other of the transverse coils is  
6 interleaved with the bottom portion.
- 1 55. The coil of claim 48 in which the central  
2 substantially solenoidal coil is partitioned into  
3 first, second, third, fourth, and fifth portions,  
4 and each of the transverse coils is partitioned  
5 into outer and inner portions, the outer portions  
6 surrounding the respective inner portions; the  
7 outer portion of a first of the transverse coils  
8 interleaved with the first and second portions,  
9 the outer portion of the other of the transverse  
10 coils interleaved with the fourth and fifth  
11 portions, the inner portion of the first of the  
12 transverse coils interleaved with the first  
13 portion, and the inner portion of the other of the  
14 transverse coils interleaved with the fifth  
15 portion.
- 1 56. An inclined-turn axial coil assembly having an  
2 axis defining and connecting a top and a bottom of

3 a central coil of the assembly, a first plane  
4 containing the axis defining and separating a  
5 front and a back of the assembly, the turns of the  
6 central coil disposed so as to have substantially  
7 reflectional symmetry with respect to a second  
8 plane perpendicular to the axis and bisecting the  
9 assembly, each of the turns being substantially  
10 reflectionally symmetrical with respect to a third  
11 plane perpendicular to the first and second  
12 planes, the turns each defining a plane having an  
13 angle of inclination defined by the intersection  
14 with the second plane, the intersections of the  
15 central coil turns all being to the front of the  
16 assembly, and the angle of inclination increasing  
17 for turns further and further from the second  
18 plane, said turns extending to a first distance  
19 from the second plane.

1 57. The axial coil assembly of claim 56 further  
2 comprising a pair of end coils at respective ends  
3 of the central coil and more distant from the  
4 second plane than said first distance, the turns  
5 thereof each defining a plane with an angle of  
6 inclination defined by the intersection with the  
7 second plane, the intersections of the end coil  
8 turns all being to the back of the assembly.

1 58. The assembly of claim 56 in which said central  
2 coil is substantially round in cross section.

1 59. The assembly of claim 56 in which said central  
2 coil is substantially trapezoidal in cross  
3 section.

1 60. The assembly of claim 56 further comprising a  
2 coilform, said coilform made from a material



3 selected from the set consisting of alumina,  
4 silicon nitride, zirconia, alumina-silica-boria  
5 glasses, borosilicate glasses, machinable glasses,  
6 plastic composites having at least 10% carbon  
7 fiber content, plastic composites having more than  
8 25% ceramic fiber content, and plastic composites  
9 having density greater than 2.0 g/cm<sup>3</sup>.

- 1 61. A non-ferromagnetic transverse gradient coil  
2 system having a central axis, said system  
3 comprising:  
4 an even number of solenoidal-like central  
5 axial assemblies having a major diameter wound on  
6 rigid coilforms having axial coil axes parallel to  
7 said central axis and positioned such that the  
8 distance between said central axis and each said  
9 axial coil axis is greater than the major diameter  
10 of said axial coils, the assemblies arranged  
11 substantially symmetrical with respect to 180°  
12 rotation about the central axis, the assemblies  
13 being substantially symmetrical with respect to  
14 reflection through a first plane perpendicular to  
15 said central axis;  
16 each of said assemblies further characterized  
17 in that for each of said assemblies, its axial  
18 coil axis defines and connects a top and a bottom  
19 of a central coil of the assembly, a second plane  
20 contains the axis defining and separating a front  
21 toward the central axis and a back of the assembly  
22 outward from the central axis, each of the turns  
23 of the central coil of the assembly being  
24 substantially reflectionally symmetrical with  
25 respect to a third plane perpendicular to the  
26 first and second planes, the turns each defining a  
27 plane having an angle of inclination defined by  
28 the intersection with the second plane, the

29 intersections of the central coil turns all being  
30 toward the central axis, and the angle of  
31 inclination increasing for turns further and  
32 further from the second plane, said turns  
33 extending to a first distance from the second  
34 plane.

1 62. The system of claim 61 in which each of the said  
2 assemblies further comprises a pair of end coils  
3 at respective ends of the central coil and more  
4 distant from the second plane than said first  
5 distance, the turns thereof each defining a plane  
6 with an angle of inclination defined by the  
7 intersection with the second plane, the  
8 intersections of the end coil turns all being  
9 outward from the central axis.

1 63. The system of claim 61 in which each said central  
2 coil is substantially round in cross section.

1 64. The system of claim 61 in which each said central  
2 coil is substantially trapezoidal in cross  
3 section.

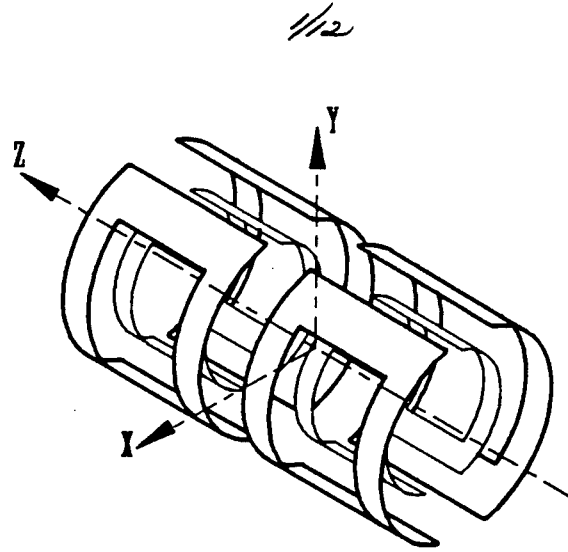

Figure 1 Prior Art

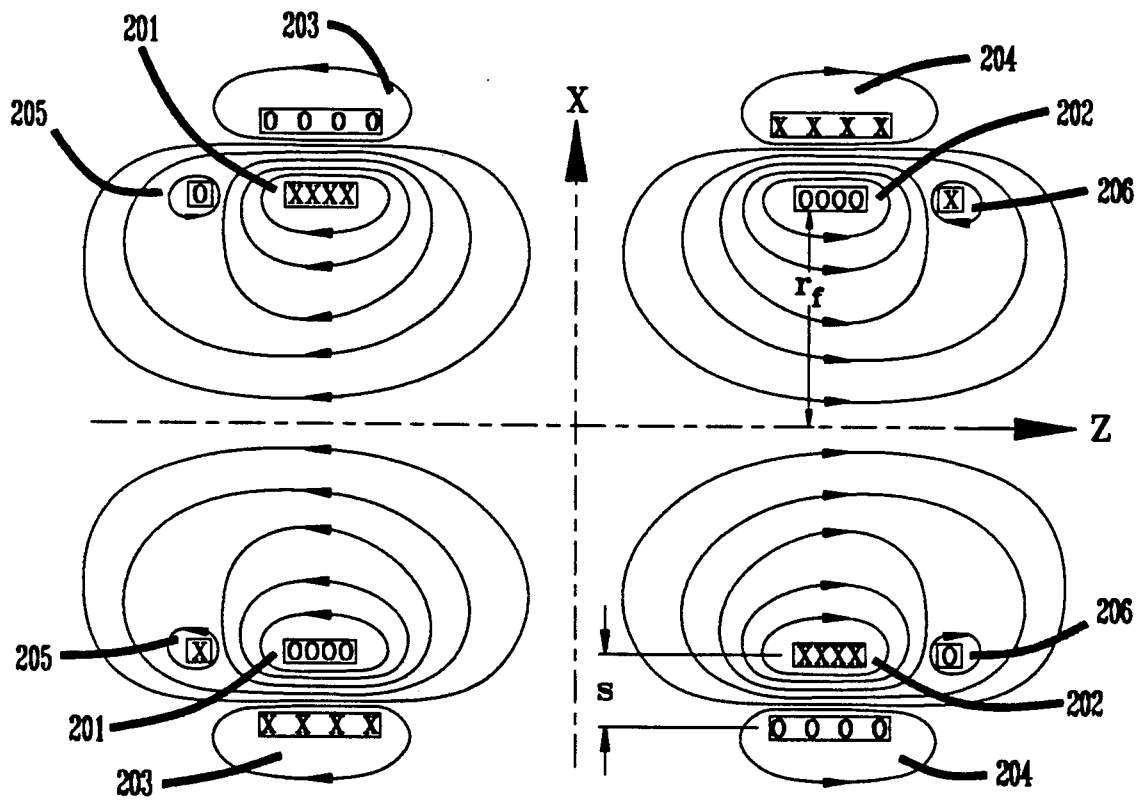

Figure 2 Prior Art

2/12

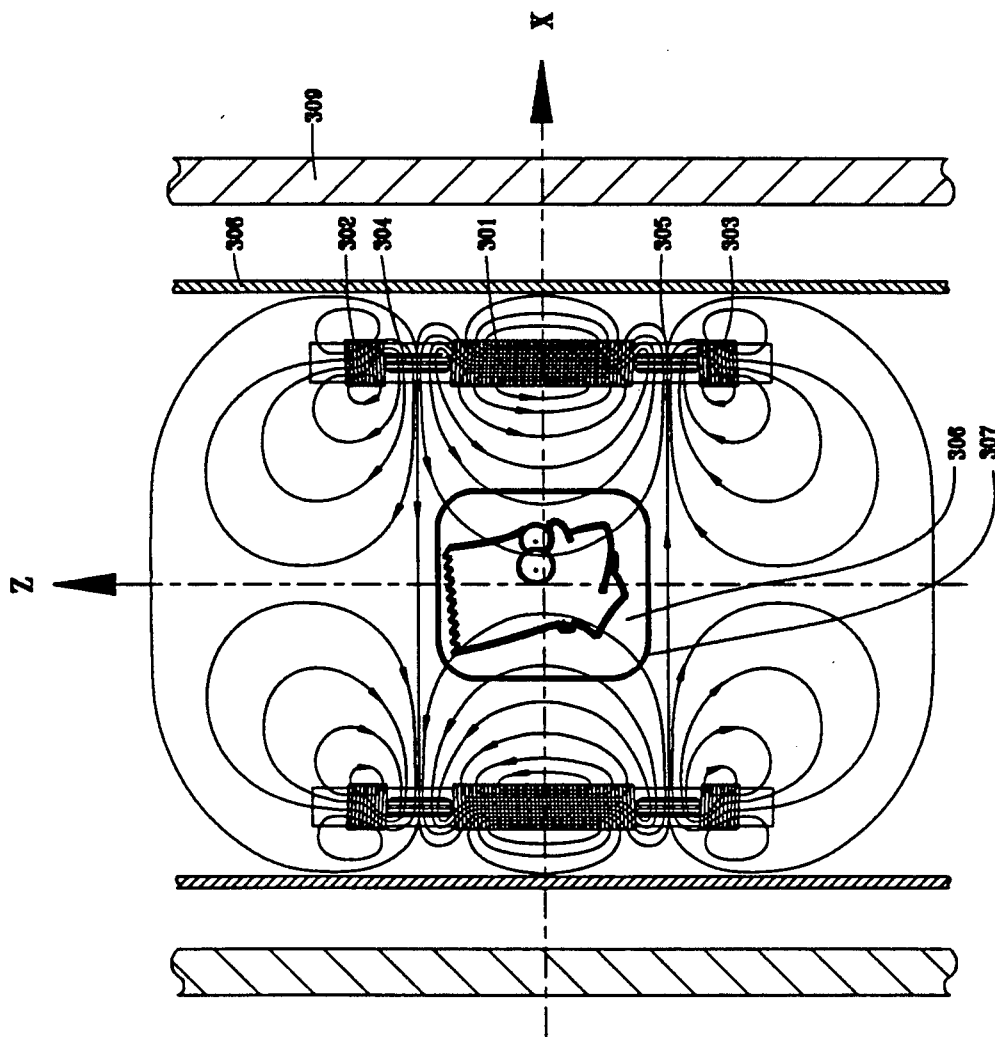

Figure 3

3/2

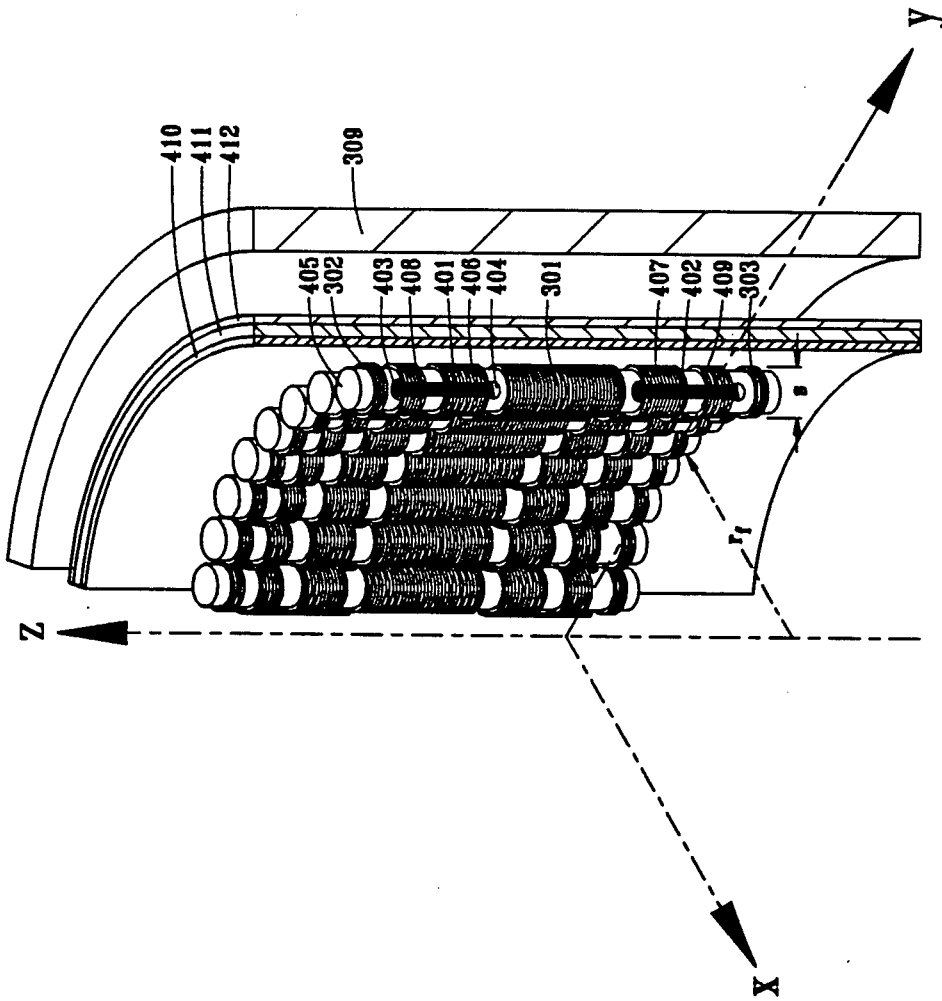

Figure 4

4/2

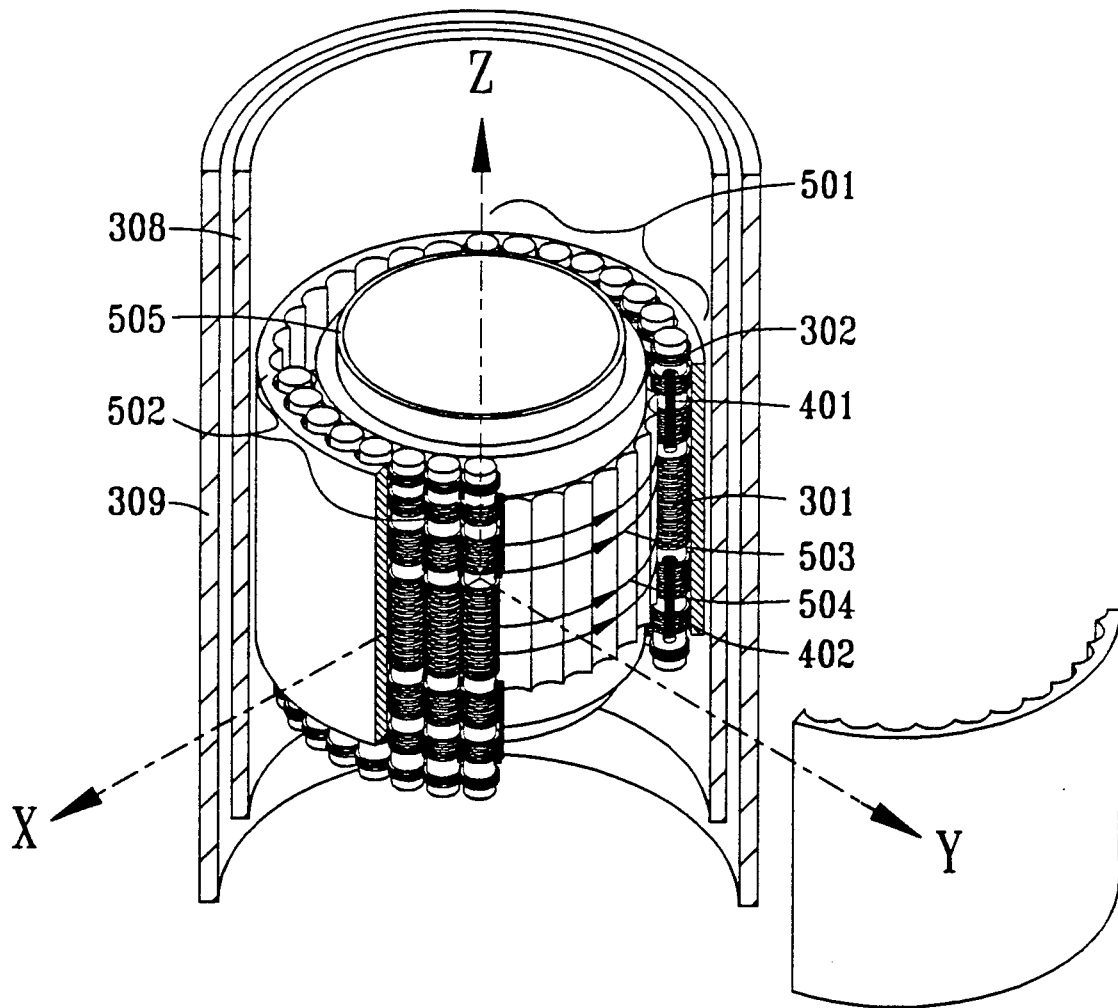

Figure 5

5/12

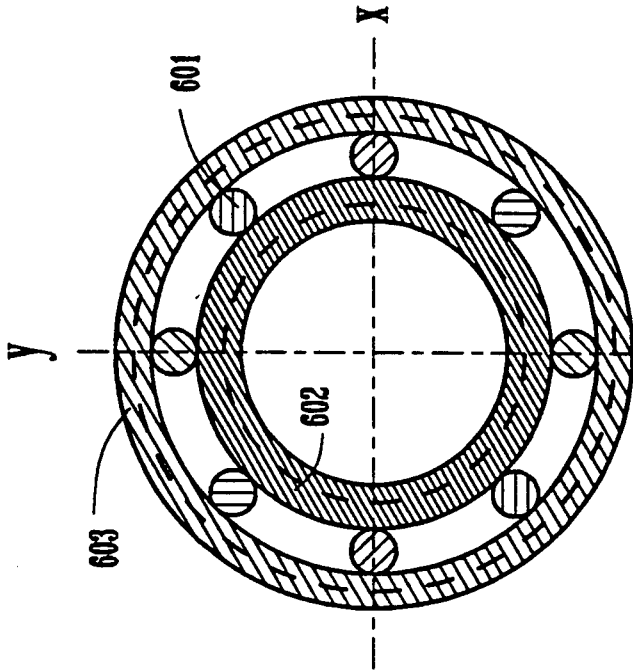

Figure 6b

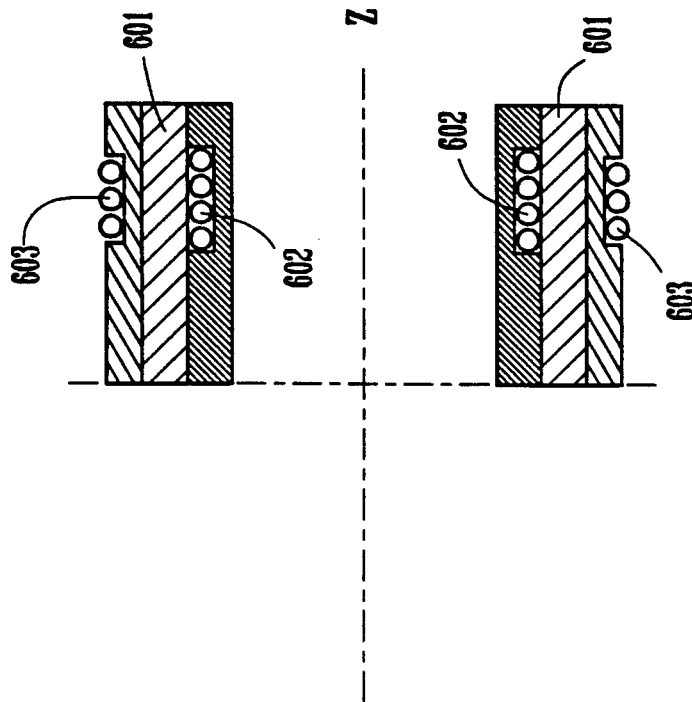

Figure 6a

6/12

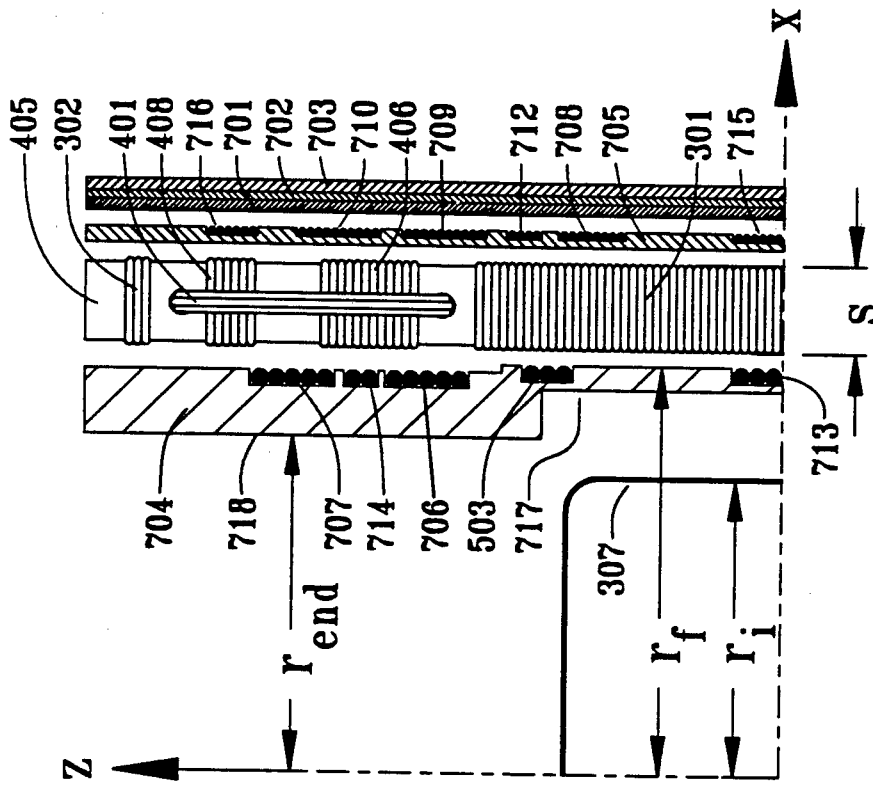

Figure 7



7/2

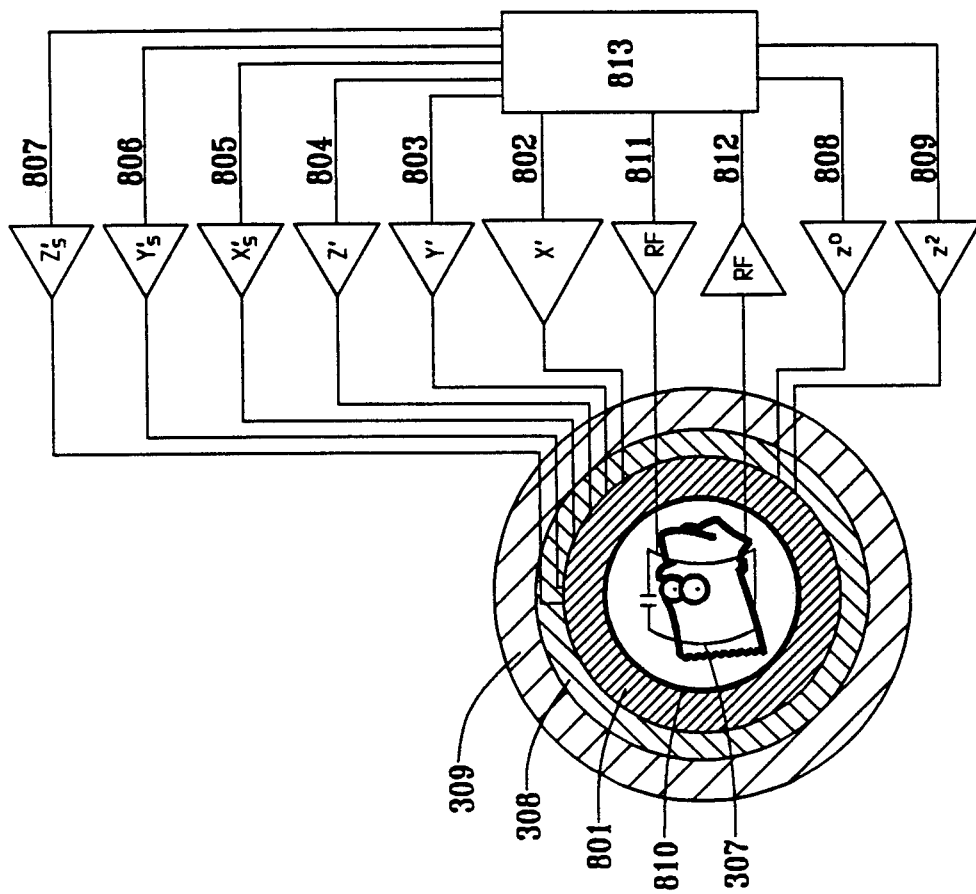

Figure 8

8/12

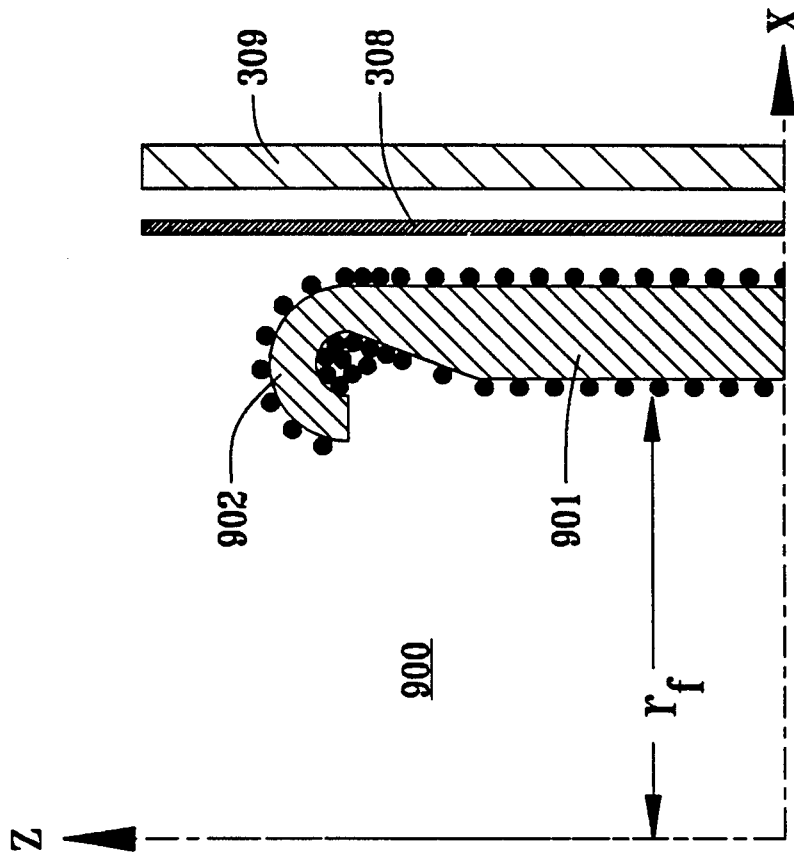

Figure 9

9/2

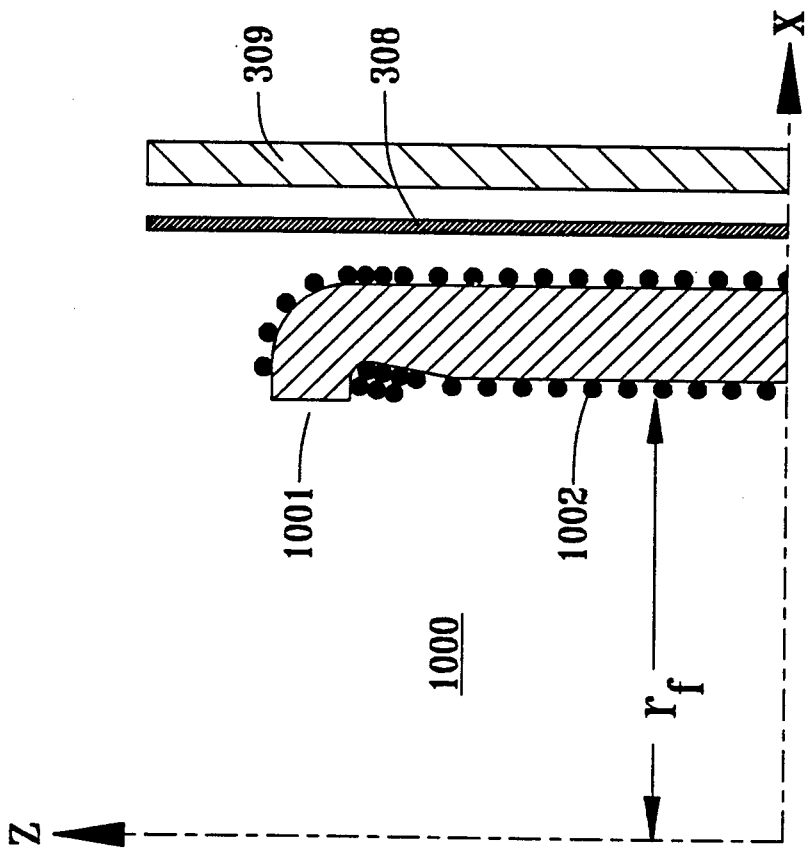

Figure 10

10/2

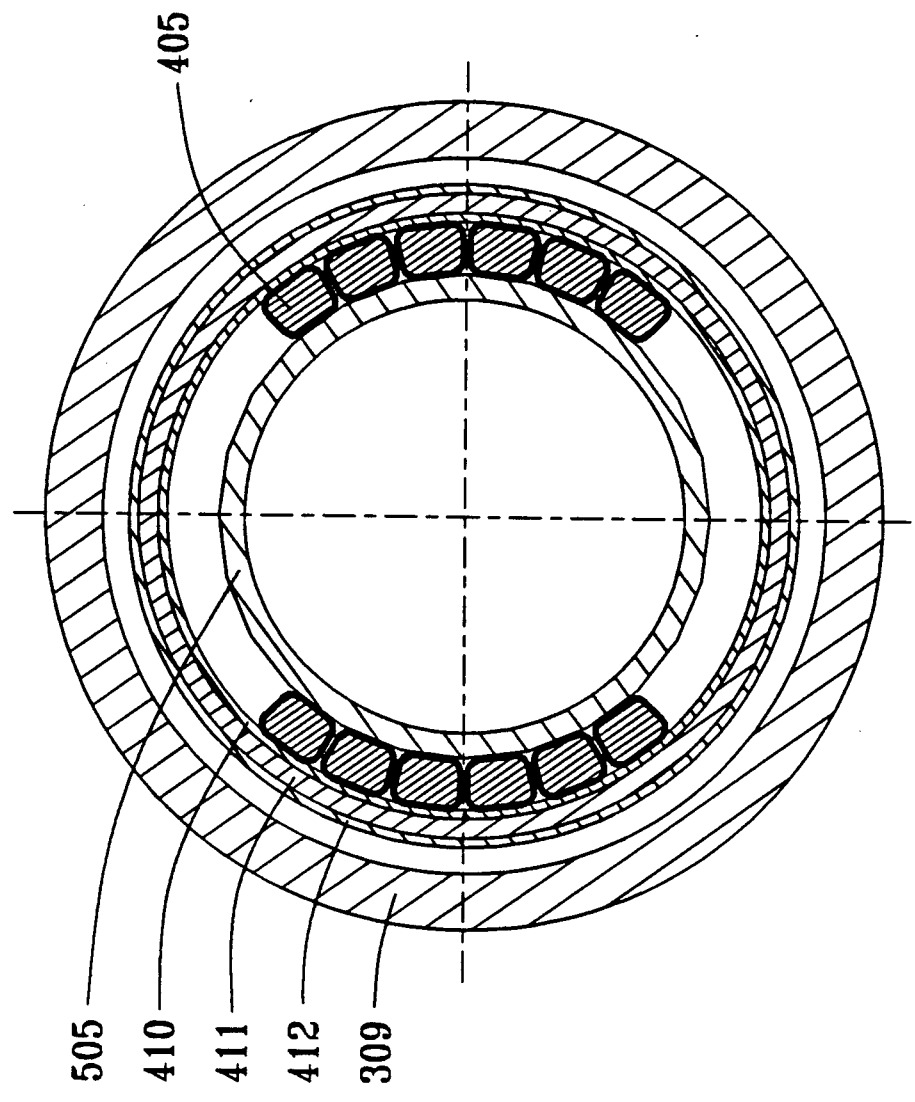

Figure 11

11/12

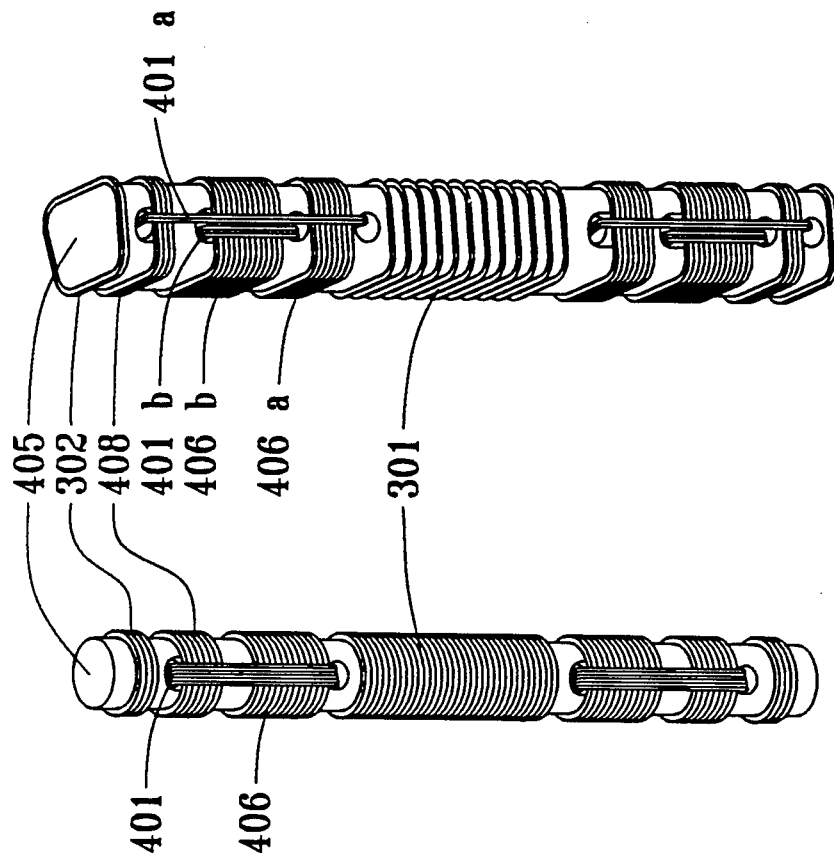

Figure 12a Figure 12b

12/12

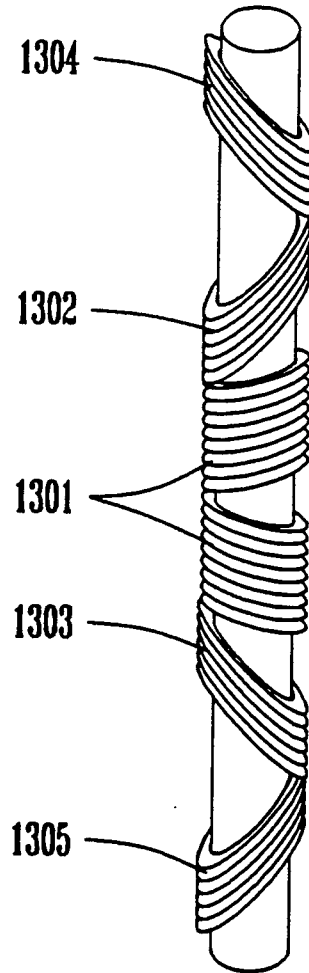

Figure 13

INTERNATIONAL SEARCH REPORT

International application No.  
PCT/US93/04574

**A. CLASSIFICATION OF SUBJECT MATTER**

IPC(5) :G01R 33/20  
US CL :324/318, 322 300; 335/299; 336/225

According to International Patent Classification (IPC) or to both national classification and IPC

**B. FIELDS SEARCHED**

Minimum documentation searched (classification system followed by classification symbols)

U.S. : 324/318-322, 300; 335/282, 296-301; 336/180, 189, 199, 208, 225, 228

Documentation searched other than minimum documentation to the extent that such documents are included in the fields searched

Electronic data base consulted during the international search (name of data base and, where practicable, search terms used)

APS (Terms: shield, gradient, solenoid, rf)

**C. DOCUMENTS CONSIDERED TO BE RELEVANT**

Category*	Citation of document, with indication, where appropriate, of the relevant passages	Relevant to claim No.
A	US, A, 4,910,462 (Roemer et al) 20 March 1990, See Fig. 1a.	1-19
A	US, A, 4,820,988 (Crooks et al) 11 April 1989, fig. 2.	1-19
A,P	US, A, 5,166,619 (Ries) 24 November 1992, figs. 3-4.	1-19
<u>Y</u> A	US, A, 3,237,090 (Royer et al) 22 February 1966, fig. 7.	<u>20-25,48</u> 26-30

Further documents are listed in the continuation of Box C.  See patent family annex.

* Special categories of cited documents:	T	later document published after the international filing date or priority date and not in conflict with the application but cited to understand the principle or theory underlying the invention
*A* document defining the general state of the art which is not considered to be part of particular relevance	X*	document of particular relevance; the claimed invention cannot be considered novel or cannot be considered to involve an inventive step when the document is taken alone
*E* earlier document published on or after the international filing date	Y*	document of particular relevance; the claimed invention cannot be considered to involve an inventive step when the document is combined with one or more other such documents, such combination being obvious to a person skilled in the art
*L* document which may throw doubts on priority claim(s) or which is cited to establish the publication date of another citation or other special reason (as specified)	*Z*	document member of the same patent family
*O* document referring to an oral disclosure, use, exhibition or other means		
*P* document published prior to the international filing date but later than the priority date claimed		

Date of the actual completion of the international search

21 October 1993

Date of mailing of the international search report

26 NOV 1993

Name and mailing address of the ISA/US  
Commissioner of Patents and Trademarks  
Box PCT  
Washington, D.C. 20231

Facsimile No. NOT APPLICABLE

Authorized officer

KENNETH WIEDER

Telephone No. (703) 305-4900

## INTERNATIONAL SEARCH REPORT

International application No.  
PCT/US93/04574

C (Continuation). DOCUMENTS CONSIDERED TO BE RELEVANT		
Category*	Citation of document, with indication, where appropriate, of the relevant passages	Relevant to claim No.
<u>Y</u> A	US, A, 2,498,475 (Adams) 21 February 1950, fig. 1.	<u>20-25, 48</u> 26-30
A	US, A, 3,924,211 (Ioffe et al) 02 December 1975, figs. 5-6 and 7-9.	20-40
A	US, A, 2,354,331 (Polydoroff) 25 July 1944, figs. 2 and 4.	31-40
Y	US, A, 4,514,586 (Waggoner) 30 April 1985, col. 2 lines 37-46.	41
Y	US, A, 4,920,011 (Ogawa et al) 24 April 1990, figs. 4-5.	41
Y,P	US, A, 5,132,621 (Kang et al) 21 July 1992, col. 10 line 35 to col. 11 line 35.	41
Y	US, A, 4,646,046 (Vavrek et al) 24 February 1987, fig. 6.	41
Y	JP, A, 54-38792 (Hitachi) 23 March 1979, abstract.	41
Y	US, A, 4,768,008 (Purcell et al) 30 August 1988, figs. 3-4.	43
A	US, A, 4,935,714 (Vermilyea) 19 June 1990, fig. 4.	43
Y	US, A, 4,965,521 (Egloff) 23 October 1990, fig. 1a.	44-45
Y	US, A, 4,642,569 (Hayes et al) 10 February 1987, fig. 1.	44-45
A	US, A, 4,876,510 (Siebold et al) 24 October 1989, col 3 lines 24-25.	43-45
X	US, A, 4,733,189 (Punchard et al) 22 March 1988, fig. 4.	46
<u>X</u> Y	US, A, 5,084,676 (Saho et al) 28 January 1992, fig. 1.	<u>46</u> 47
A,T	US, A, 5,235,283 (Lehne et al) 10 August 1993, fig. 4.	47
Y	US, A, 4,954,781 (Hirata) 04 September 1990, fig. 18.	47
Y	US, A, 5,061,891 (Totsuka et al) 29 October 1991, figs. 6 and 8.	48
Y,P	US, A, 5,198,769 (Frese et al) 30 March 1993, fig. 5	56-64
Y	US, A, 4,766,383 (Fox et al) 23 August 1988, fig. 4b.	56-64
Y,P	US, A, 5,185,577 (Minemura) 09 February 1993, fig 9a.	56-64
A,T	US, A, 5,225,782 (Laskaris et al) 06 July 1993, fig. 1.	46



## INTERNATIONAL SEARCH REPORT

International application No.  
PCT/US93/04574**Box I Observations where certain claims were found unsearchable (Continuation of item 1 of first sheet)**

This international report has not been established in respect of certain claims under Article 17(2)(a) for the following reasons:

1.  Claims Nos.:  
because they relate to subject matter not required to be searched by this Authority, namely:
2.  Claims Nos.: 42  
because they relate to parts of the international application that do not comply with the prescribed requirements to such an extent that no meaningful international search can be carried out, specifically:  
  
Please See Extra Sheet.
3.  Claims Nos.:  
because they are dependent claims and are not drafted in accordance with the second and third sentences of Rule 6.4(a).

**Box II Observations where unity of invention is lacking (Continuation of item 2 of first sheet)**This International Searching Authority found multiple inventions in this international application, as follows:  
(Form PCT/ISA/206 Previously Mailed.)

- I. Figs. 3-5, 7, 11 describe solenoids drawn to claims 1-19, 44-47.  
II. Fig. 6 describes shields drawn to claims 41-43.  
III. Fig. 9 describes c-coils drawn to claims 31-40.  
IV. Fig. 10 describes u-coils drawn to claims 20-30.  
V. Fig. 12 describes alternate solenoids drawn to claims 48-55.  
VI. Fig. 13 drawn to inclined solenoids drawn to claims 56-64.

1.  As all required additional search fees were timely paid by the applicant, this international search report covers all searchable claims.
2.  As all searchable claims could be searched without effort justifying an additional fee, this Authority did not invite payment of any additional fee.
3.  As only some of the required additional search fees were timely paid by the applicant, this international search report covers only those claims for which fees were paid, specifically claims Nos.:
4.  No required additional search fees were timely paid by the applicant. Consequently, this international search report is restricted to the invention first mentioned in the claims; it is covered by claims Nos.:

Remark on Protest

The additional search fees were accompanied by the applicant's protest.

No protest accompanied the payment of additional search fees.

**BOX I. OBSERVATIONS WHERE CLAIMS WERE FOUND UNSEARCHABLE:**

2. Where no meaningful search could be carried out, specifically:

Claim 42 lacks clarity under PCT article 6 because: it is not clear whether "said element" (which lacks antecedent basis) are disposed at different radii at the same time, or if the element is used at  $r_{min}$  and later at  $r_{max}$ . If said element is used in the former case, then it is unclear how the foil can have a radius between  $r_{min}$  and  $r_{max}$ . Does the foil physically intersect said element? Moreover, there is no support for such an arrangement between said element and the foil.