



US 20130069403A1

(19) **United States**  
(12) **Patent Application Publication**  
**Walter**

(10) **Pub. No.: US 2013/0069403 A1**  
(43) **Pub. Date: Mar. 21, 2013**

(54) **CHILD SEAT FOR A SHOPPING CART**

(52) **U.S. Cl.**  
USPC ..... 297/256.17

(75) Inventor: **Ivor Michel Walter**, Boulder, CO (US)

(73) Assignee: **AMSA, INC., DBA VERSACART, INC.**, Boulder, CO (US)

(57) **ABSTRACT**

(21) Appl. No.: **13/458,438**

(22) Filed: **Apr. 27, 2012**

**Related U.S. Application Data**

(63) Continuation-in-part of application No. 29/402,205, filed on Sep. 21, 2011, now Pat. No. D,658,841.

**Publication Classification**

(51) **Int. Cl.**  
**A47D 1/10** (2006.01)

A child seat for a shopping cart comprises a gate, a back rest, two arms and a seat. The arms connect to the gate at one end and the back rest at the other. The arms connect to the gate at an angle, which provides resistance so that the back rest does not fall while buckling the child into the seat. The arms terminate in a chamber, which encompasses the back rest and allows the back rest to fold. One end of the seat terminates in a channel, which encompasses the base wire of the back rest, allowing the back rest to rotate. The second end of the seat terminates in a second channel, which encompasses attachment members on the gate, thereby allowing the seat to rotate. The attachment members include wires, which interact with a step in the second channel to lock the seat to the gate.

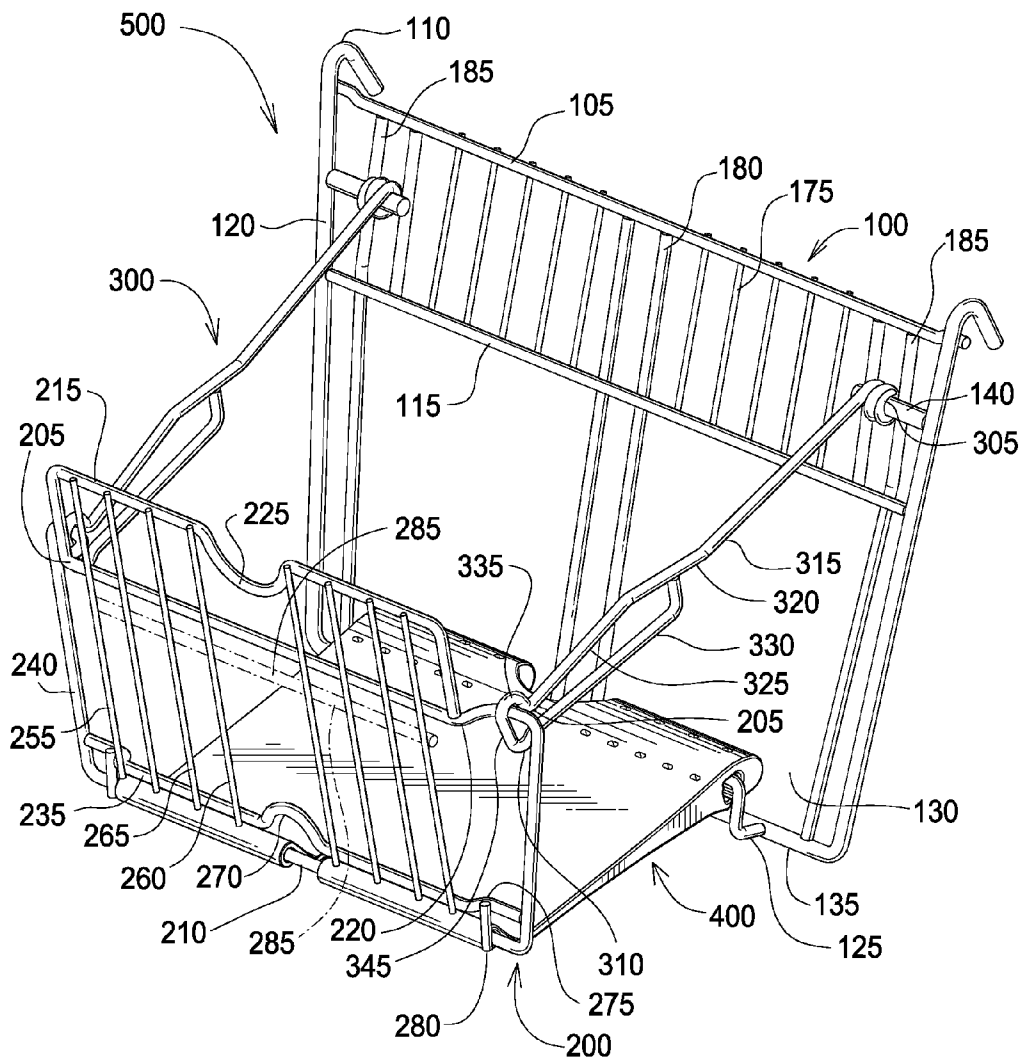

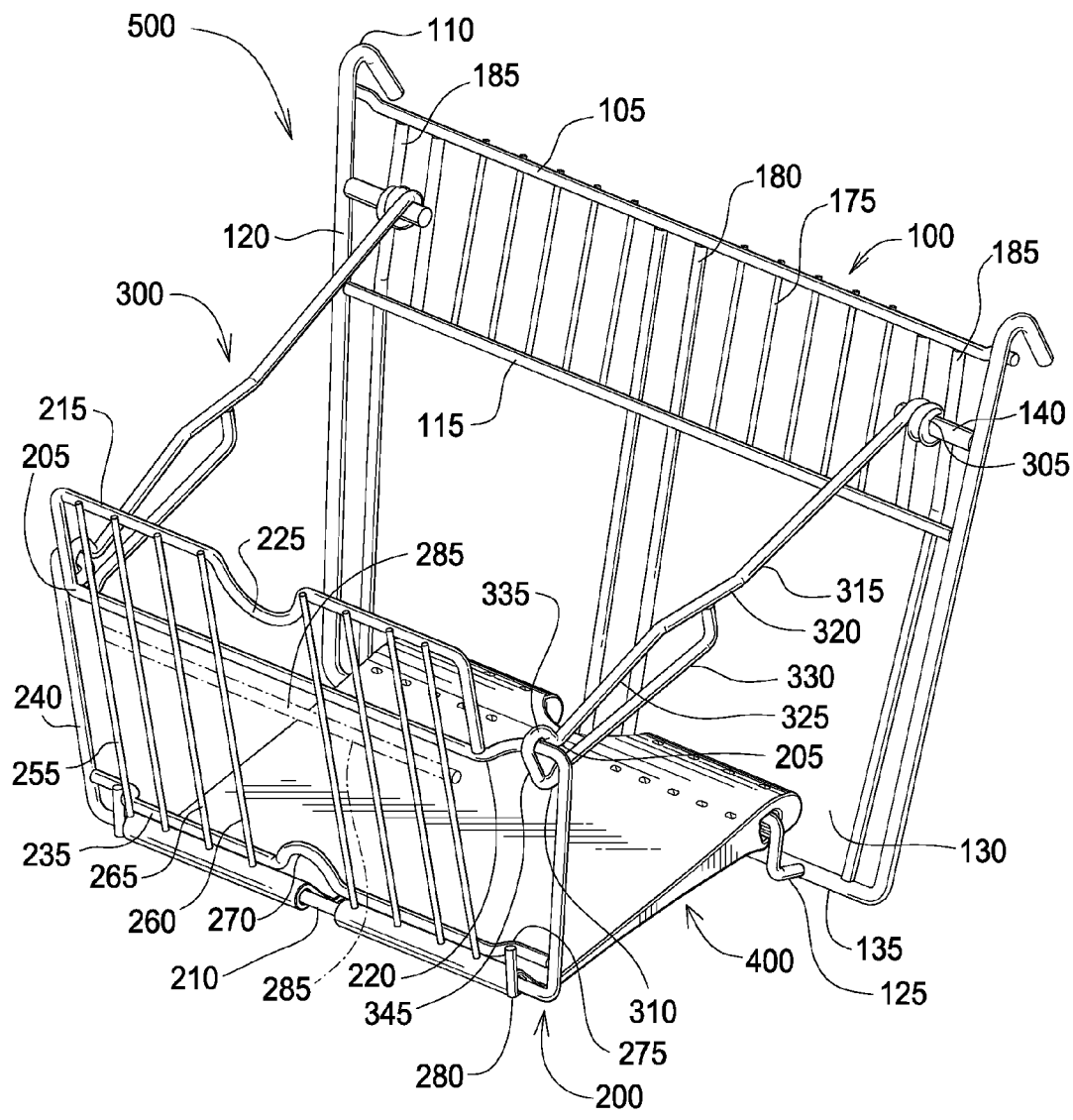

FIG. 1

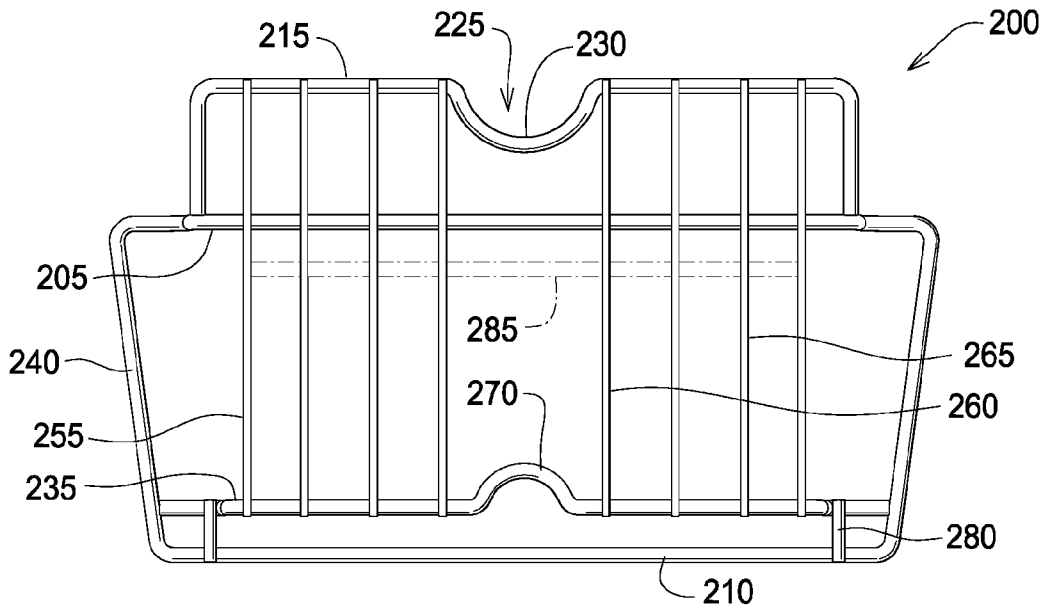

FIG. 2

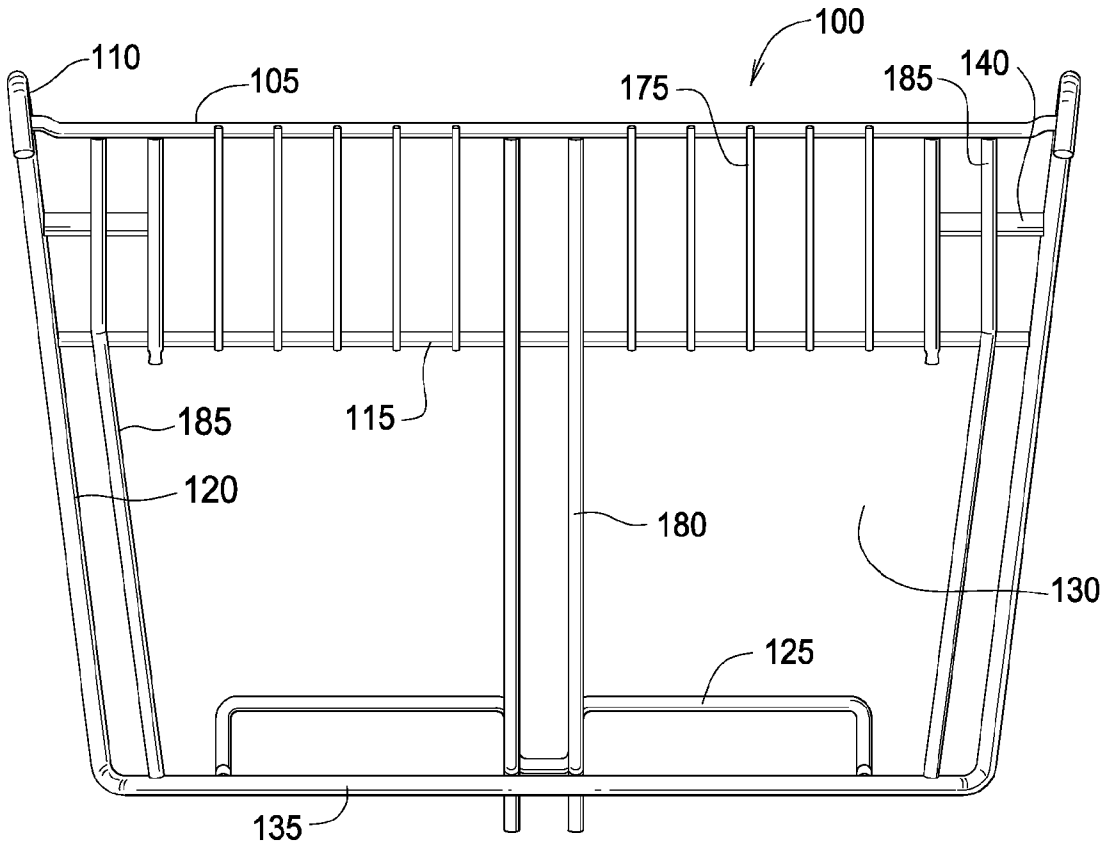

FIG. 3

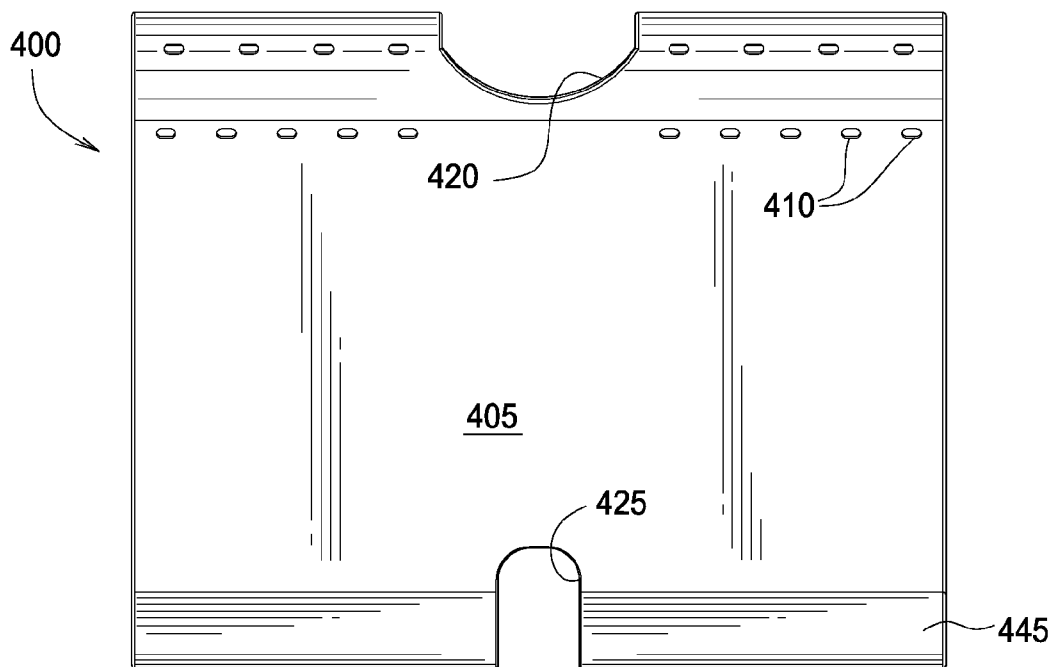

FIG. 4

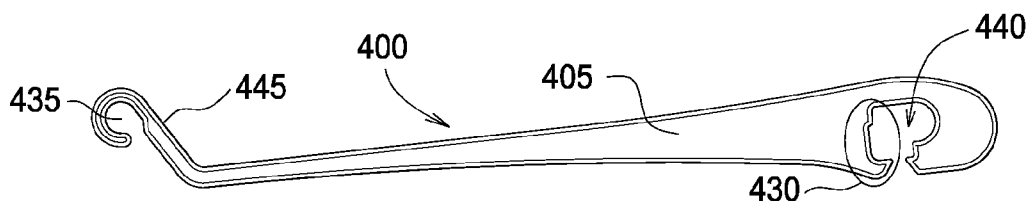

FIG. 5

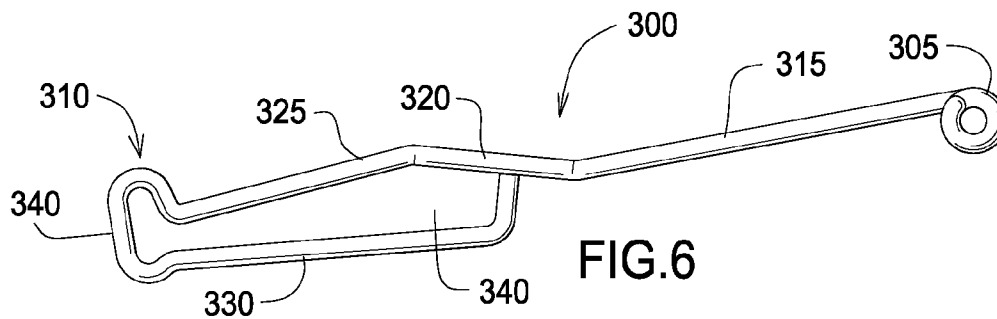

FIG. 6

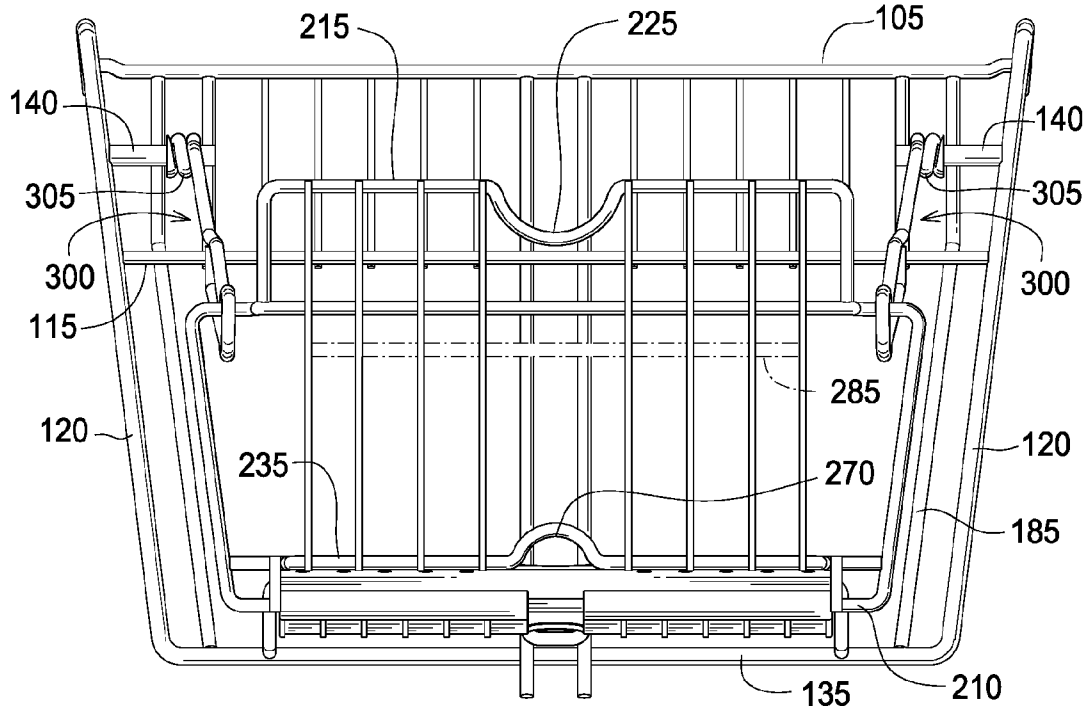

FIG. 7

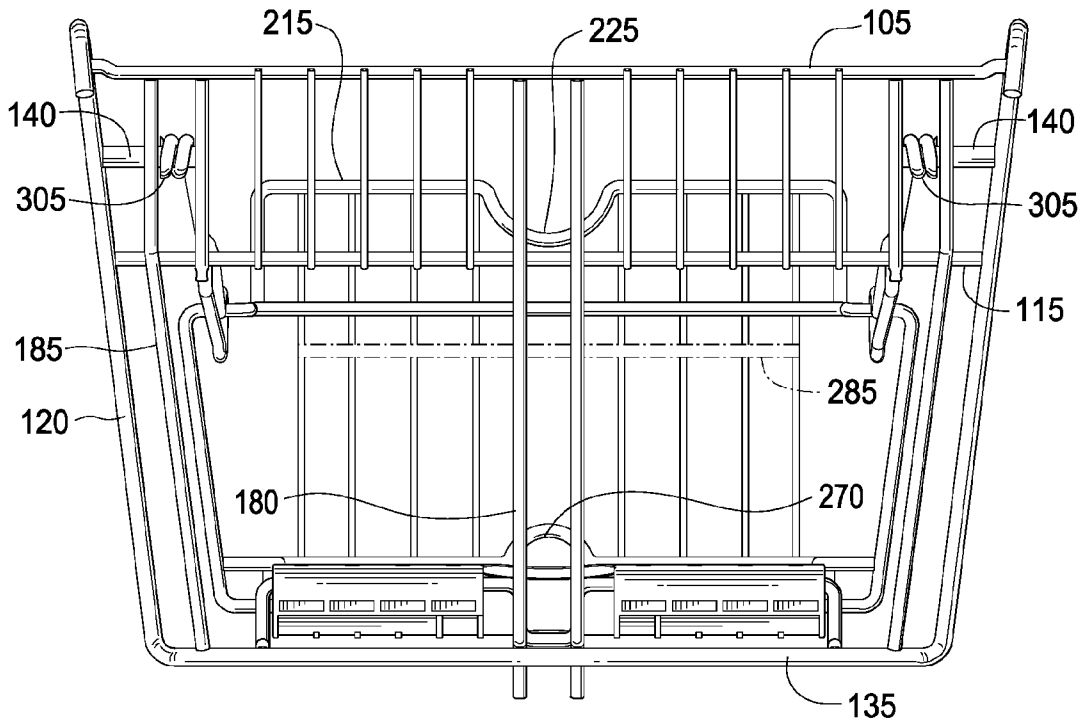
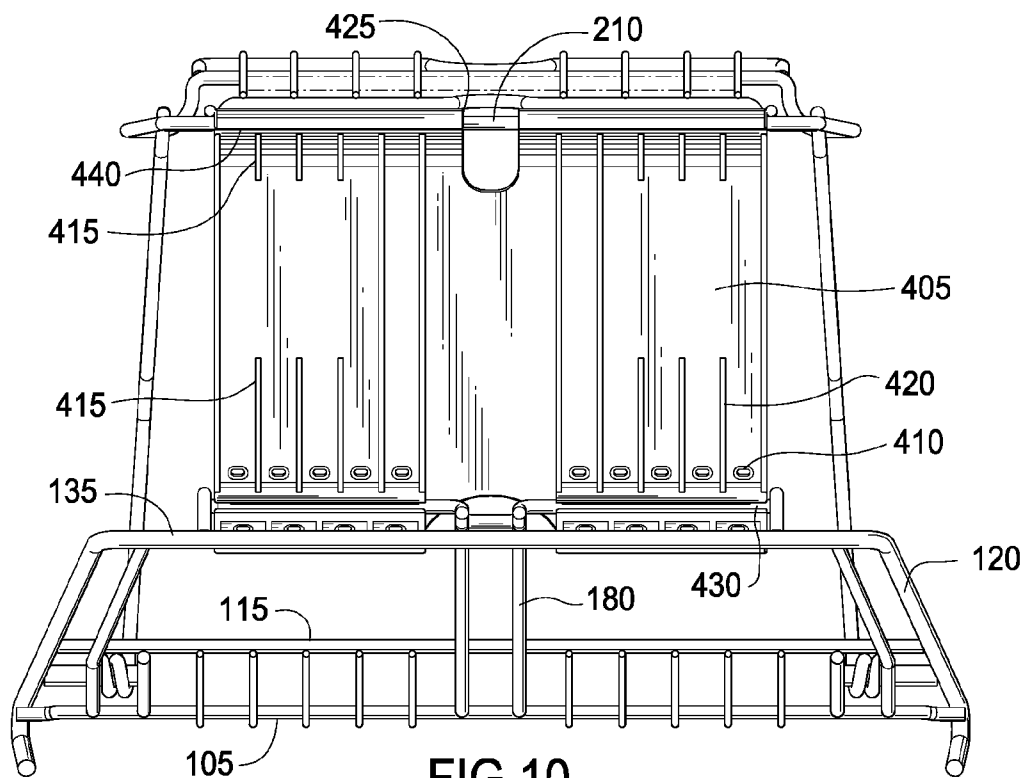
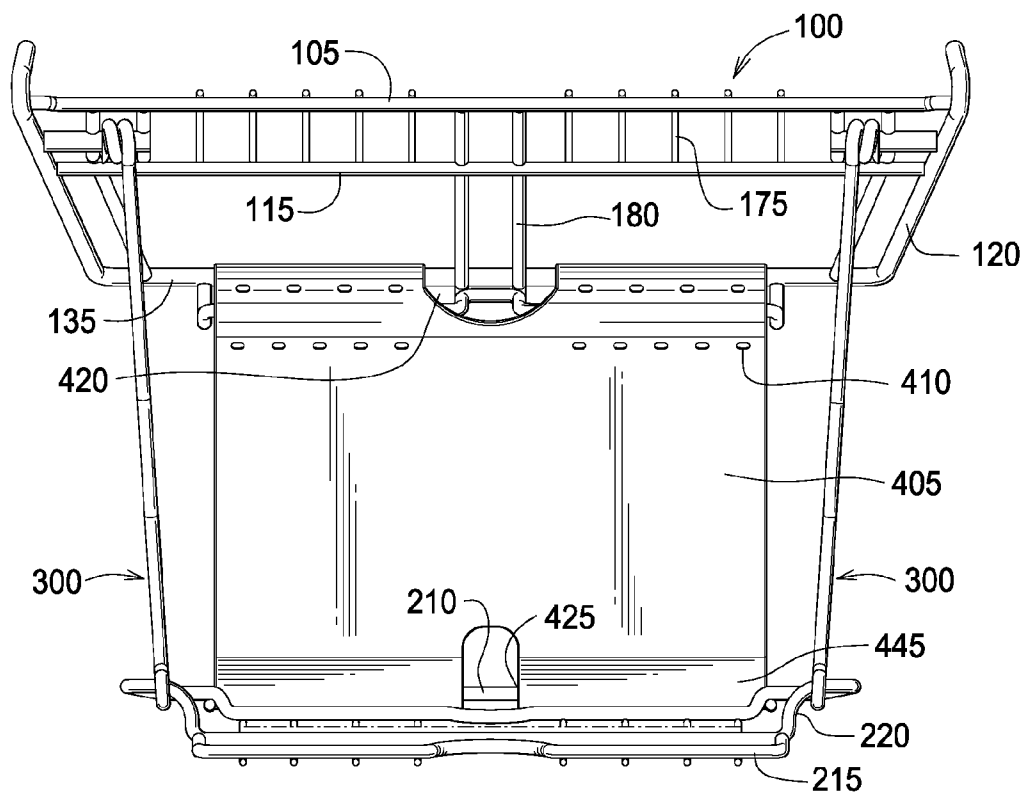

FIG. 8



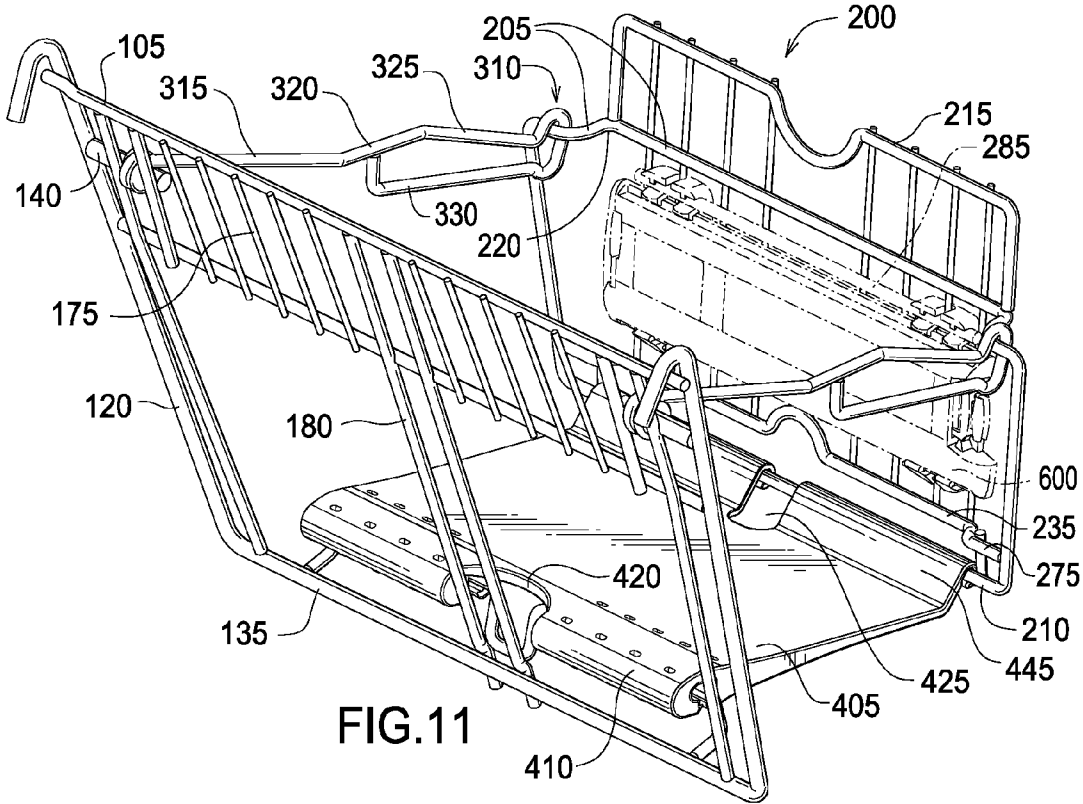

FIG. 11

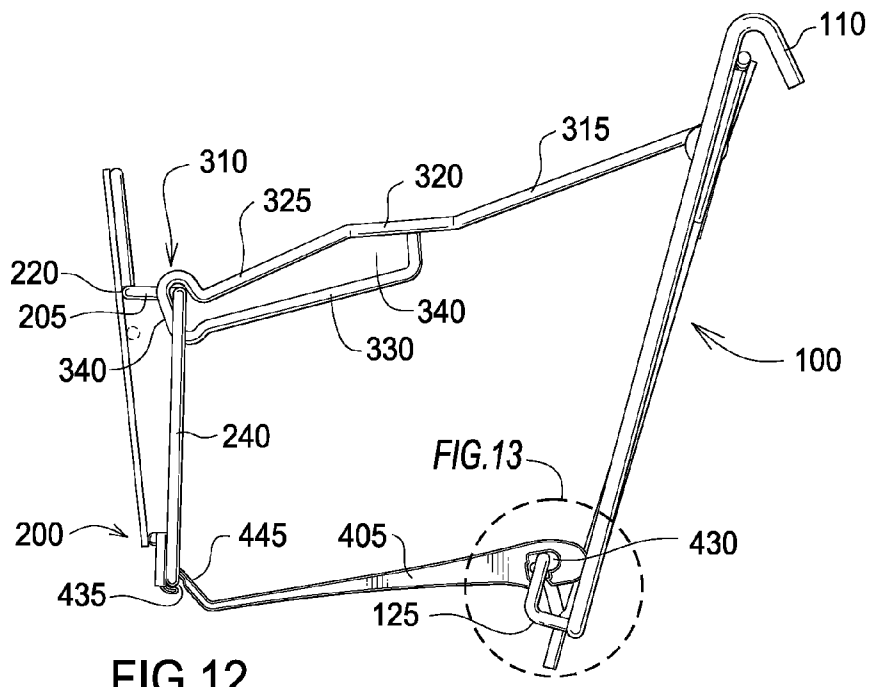

FIG. 12

FIG. 13

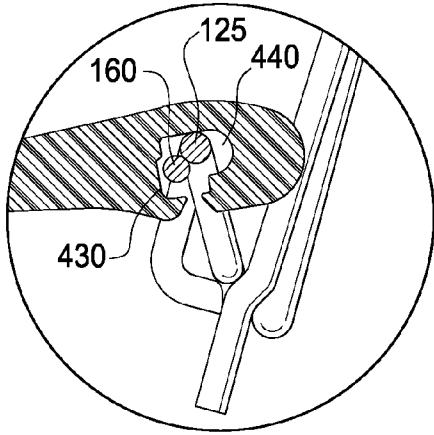

FIG. 13

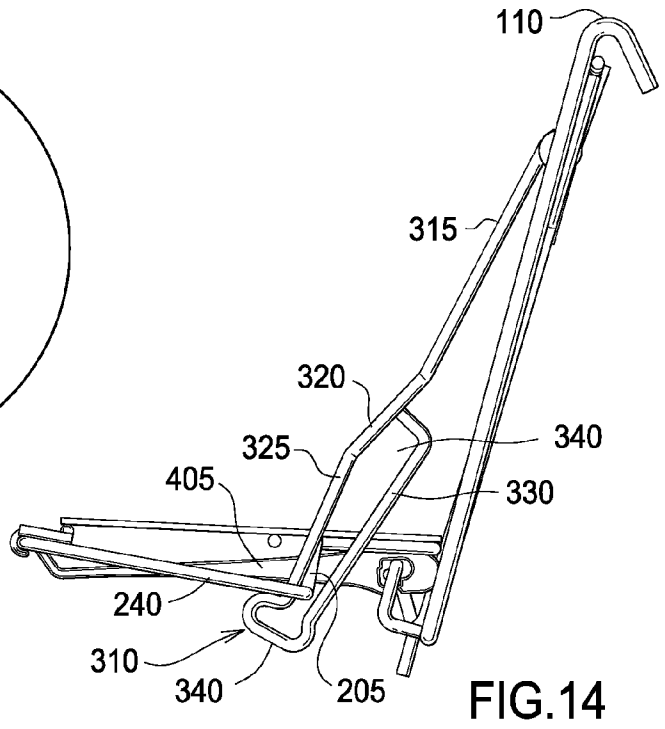

FIG. 14

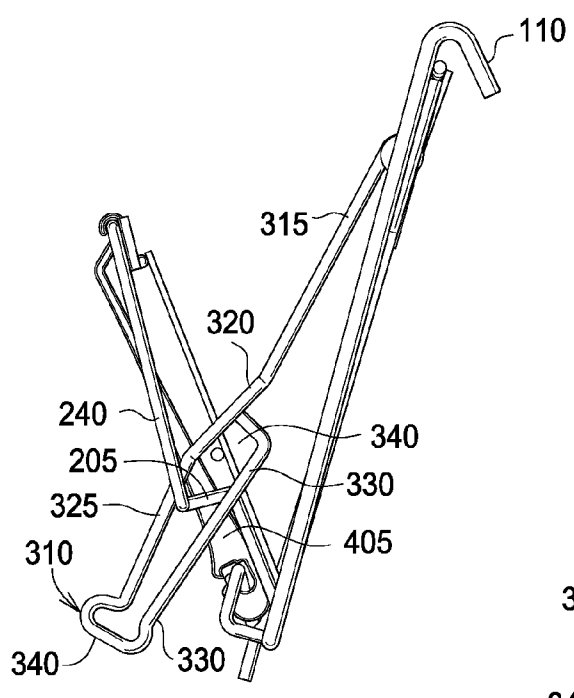

FIG. 15

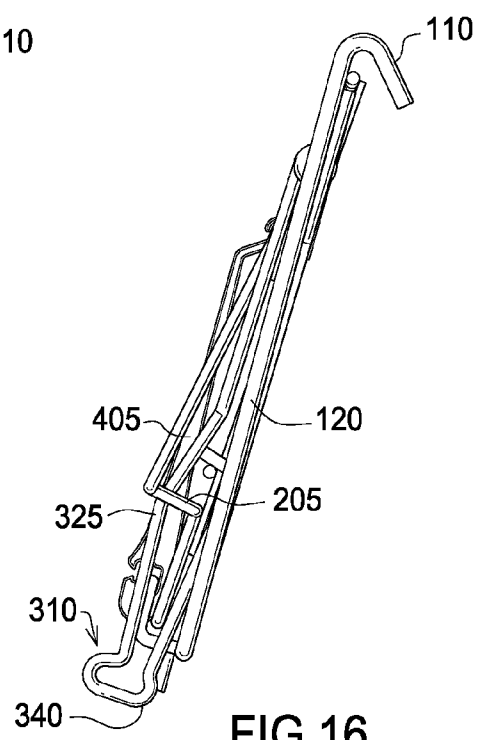

FIG. 16



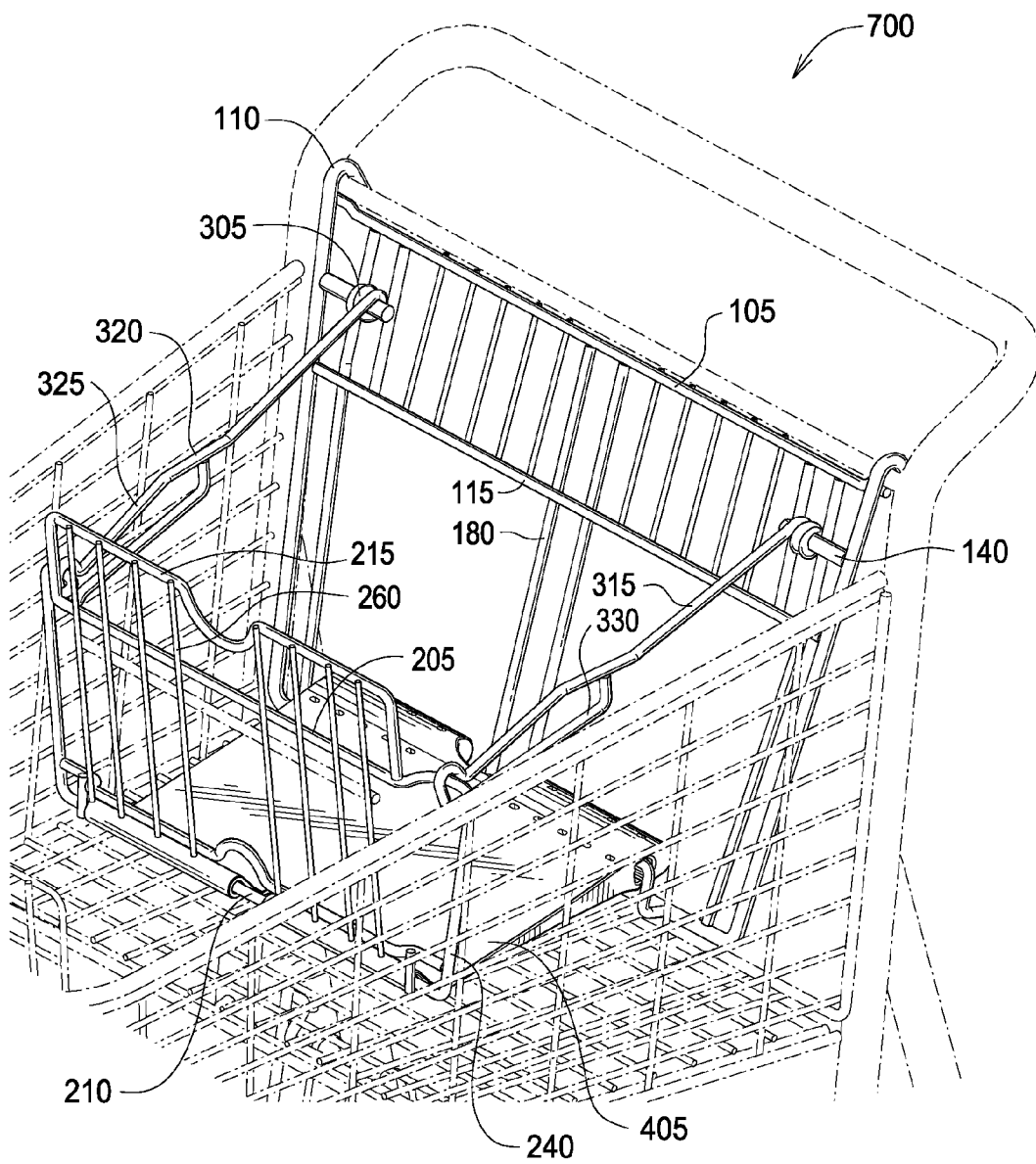

FIG.17

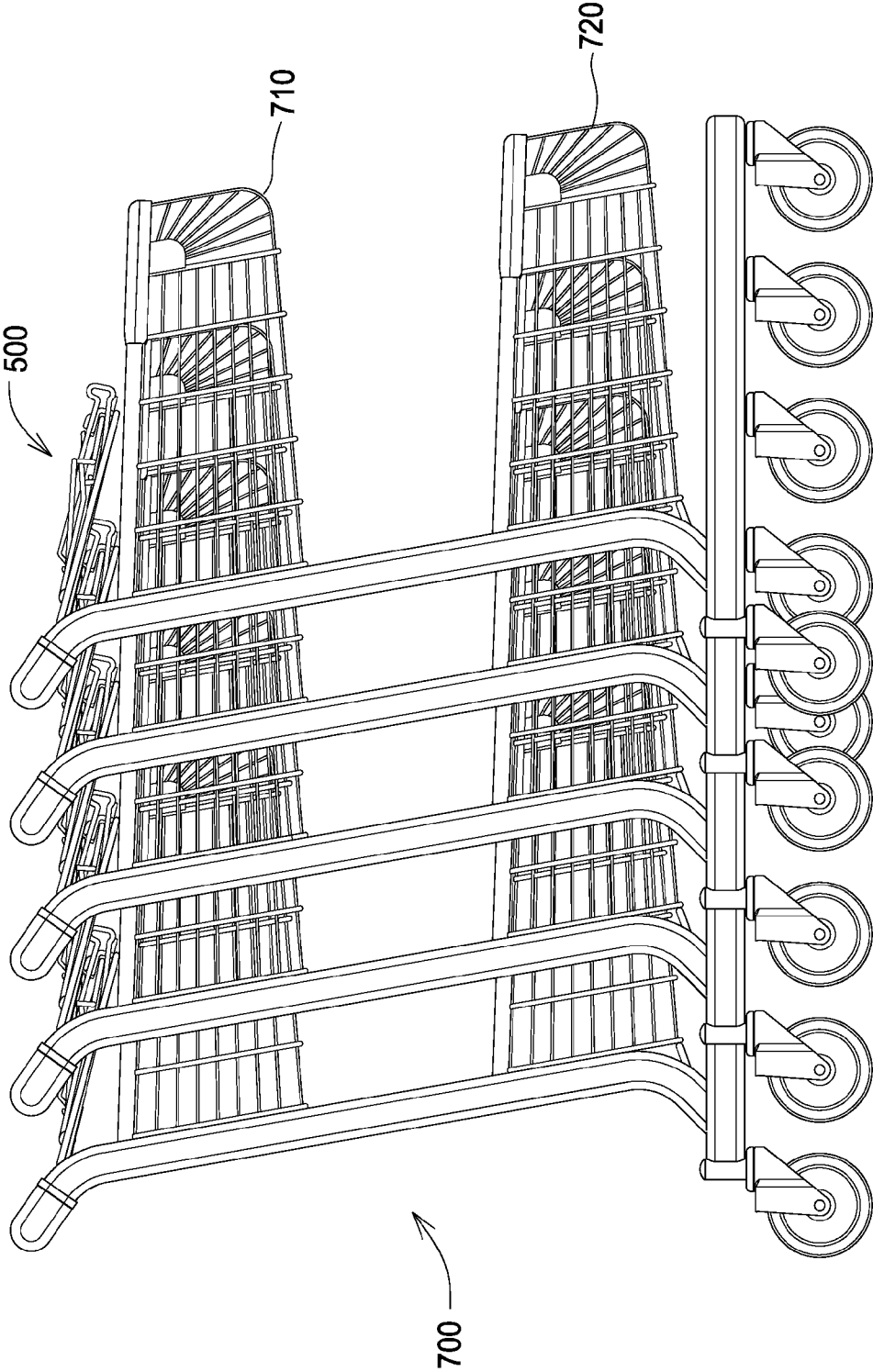

FIG.18

**CHILD SEAT FOR A SHOPPING CART**

**CROSS REFERENCE APPLICATIONS**

[0001] This application is a continuation-in-part application claiming the benefits of design application No. 29/402, 205 filed Sep. 21, 2011 and issued as U.S. Des. Pat. No. D658,841 on May 1, 2012, the disclosure of which is incorporated herein by reference for all purposes.

**BACKGROUND**

[0002] The child seats for shopping carts which are currently available have a number of limitations. Existing folding mechanisms have a bulky profile when folded, thereby negatively affecting the ability of shopping carts to nest and reducing the usable area of the shopping basket when the child seat is not in use. Further, current child seats are sized to fit in single-tiered deep-basket shopping carts.

[0003] Moreover, many current child seats are attached using methods that leave small crevices and sharp edges, allowing a child to insert his or her fingers, which may lead to injury. Existing back rests are made much taller than the span of the corresponding seat.

[0004] The foregoing example of the related art and limitations related therewith are intended to be illustrative and not exclusive. Other limitations of the related art will become apparent to those of skill in the art upon a reading of the specification and a study of the drawings.

**SUMMARY**

[0005] The following embodiments and aspects thereof are described and illustrated in conjunction with systems, tool and methods which are meant to be exemplary and illustrative, not limiting in scope. In various embodiments, one or more of the above described problems have been reduced or eliminated, while other embodiments are directed to other improvements.

[0006] The present child seat provides a number of improvements over existing child seats. In general, these improvements include, but are not limited to the following aspects. First, the child seat of the present application can be used in a shallow basket of a two-tier cart. Second, the present child seat allows the child to sit low in the basket, lowering the center of gravity making it much safer than a conventional folding child seat mechanism in a two-tier cart. Third, the child seat of the present application folds away completely, allowing maximum use of the basket area when there is no child in the cart. Finally, the present child seat is designed to fold really flat whether open or closed using the least amount of space and thus allowing tighter cart nesting and more basket clearance between upper and lower baskets.

[0007] Furthermore, the angle of the arm provides resistance so that the back rest will not easily fall forward when buckling a child into the seat. The height of the gate in relation to the span of the seat allows for both comfort and a low-profile when folded. The locking mechanism attaching the back rest to the seat allows for multiple nesting options. The unique shape of the arm allows it to have an extremely low profile when the seat is closed. This unique shape allows the seat to be flat when opened. The angle at which the seat connects to the backrest allows for a taller back rest without making the seat too long. The method used to attach the arms to the gate prevents arms from rotating or moving diagonally,

thereby providing more stability. This same method minimizes sharp edges and small crevices, reducing the risk of injury to a small child.

[0008] In addition to the exemplary aspects and embodiments described above, further aspects and embodiments will become apparent by reference to the accompanying drawings forming a part of this specification wherein like reference characters designate corresponding parts in the several views.

**BRIEF DESCRIPTION OF THE DRAWINGS**

[0009] FIG. 1 is a front perspective view the combined child seat and retention flap for use with a shopping cart of the present application.

[0010] FIG. 2 is a front plan view of the back rest of FIG. 1.

[0011] FIG. 3 is a front plan view of the gate of FIG. 1.

[0012] FIG. 4 is a top plan view of the base of FIG. 1.

[0013] FIG. 5 is a side plan view of the base of FIG. 4.

[0014] FIG. 6 is a side plan view of one of the arms of FIG. 1.

[0015] FIG. 7 is a front elevation view of FIG. 1

[0016] FIG. 8 is a back elevation view of FIG. 1.

[0017] FIG. 9 is a top plan view of FIG. 1.

[0018] FIG. 10 is a bottom plan view of FIG. 1.

[0019] FIG. 11 is a rear perspective view of FIG. 1.

[0020] FIG. 12 is a side elevation view of the left and right sides, which are mirror images, of the child seat in the fully open position.

[0021] FIG. 13 is a close-up view of the locking mechanism indicated in FIG. 12.

[0022] FIG. 14 is a side elevation view of the left and right sides, which are mirror images, of the child seat in a partially closed position.

[0023] FIG. 15 is a side elevation view of the left and right sides, which are mirror images, of the child seat in a partially closed position between the partially closed position on FIG. 15 and the fully closed position of FIG. 16.

[0024] FIG. 16 is a side elevation view of the left and right sides, which are mirror images, of the child seat in the folded position it is in when the carts are nested together.

[0025] FIG. 17 is a front perspective view of the combined child seat and retention flap for use with a shopping cart of FIG. 1 with the retention flap in the down position with a shopping cart shown in dotted lines.

[0026] FIG. 18 is a side elevation view of the left and right sides, which are mirror images, of a series of shopping carts including the child seat of FIG. 1 in a nested position.

[0027] Before explaining the disclosed embodiment of the present invention in detail, it is to be understood that the invention is not limited in its application to the details of the particular arrangement shown, since the invention is capable of other embodiments. Exemplary embodiments are illustrated in referenced figures of the drawings. It is intended that the embodiments and figures disclosed herein are to be considered illustrative rather than limiting. Also, the terminology used herein is for the purpose of description and not of limitation.

**DETAILED DESCRIPTION OF THE DRAWINGS**

[0028] Turning first to FIG. 1, a child seat 500 for use with a shopping cart is shown. The child seat generally comprises a gate 100, back rest 200, arms 300 and base 400.

[0029] Turning next to FIG. 2, back rest 200 includes base wire 210, top wire 215 and sides 240. A first horizontal

support member **205** and second horizontal support member **235** are located between base wire **210** and top wire **215**. First horizontal support member **205** includes upper jog **220**. Second horizontal support member **235** includes second divot **270** and lower jog **275**. Outer vertical support members **255**, intermediate vertical support members **265**, and central vertical support members **260** support extend from top wire **215** to base wire **210**. Enclosing wires **280** extend from base wire **280** to second horizontal supporting member **235**. An optional attachment bar **285** is mounted from one outer vertical support member **255** to the other below and substantially parallel to first horizontal support member. If attachment bar **285** is included, a seat belt mechanism **600** may be mounted to attachment bar **285**.

[0030] In the depicted embodiment, first horizontal support member **205** is approximately 335 mm in length. The width of back rest **200** is approximately 400 mm. The height of back rest **200** from base wire **210** to top wire **215** is approximately 195 mm. The width of upper jog **220** is approximately 30 mm. The length of top wire is approximately 270 mm. The height from first horizontal support member **205** to top wire **215** is approximately 55 mm. The height from base wire **210** to first horizontal support member **205** is approximately 140 mm. The distance from the apex of first divot **225** to top wire **215** is approximately 30 mm. The height from base wire **210** to second horizontal support member **235** is approximately 121 mm. The angle from left or right side **240** to base wire **210** is approximately 97 degrees. The radius of the bend at the intersection of left or right side **240** and base wire **210** is approximately 4 mm. The radius of second divot **270** is approximately 15 mm. The distance between enclosing wires **280** is approximately 260 mm. The length of base wire **210** is approximately 303 mm. The angle of upper jog **220** is approximately 97 degrees. The distance between top wire **215** and the furthest distance of upper jog **220** is approximately 37 mm. The distance between adjacent outer vertical support members **255** is approximately 20 mm. The distance between central vertical support members **260** is approximately 69 mm. The radius of first divot **225** is approximately 25 mm. The distance between adjacent intermediate vertical support members **265** is approximately 25 mm. A person having an ordinary level of skill in the art will understand that the disclosed measurements apply to the depicted embodiment. Differing measurements which approximately preserve the ratios inherent in the disclosed measurements are anticipated by the present disclosure.

[0031] Turning next to FIG. 3, gate **100** includes top wire **105**, base wire **135** and sides **120**. Sides **120** include hooks **110**. Intermediate wire **115** is located between top wire **105** and base wire **135**. In the depicted embodiment, intermediate wire **115** extends the entire width of gate **100**. Outer vertical support members **185** extend the entire length of gate **100**, from top wire **105** to base wire **135**. Outer vertical support members **185** run parallel to sides **120** from base wire **135** to the approximate intersection of intermediate wire **115**. Near the intersection with intermediate wire **115**, outer vertical support members become parallel to lateral vertical support members **175**. Lateral vertical support members **175** extend from top wire **105** to intermediate wire **115**. In the depicted embodiment, lateral vertical support members **175** are arranged equidistantly across the span from central vertical support members **180** to outer vertical support members **185**. The spacing of lateral vertical support members creates a mesh that a child can't put his or her hand through. Also, not

close enough for a child to get his or her finger caught in. Optionally, central vertical support members **180** may extend from top wire **105** past base wire **135** approximately 15 mm. If the extension is present, it acts as a gate stop. The intersection of outer vertical support members **185** with base wire **135** and intermediate wire **115** creates openings **130**. Attachment members **125** are mounted to base wire **135**. Attachment members **125** are stepped in relation to gate **100**, with a first portion **145** substantially perpendicular to base wire **135**, a second portion **150** substantially parallel to base wire **135**, and third portion **155** substantially perpendicular to base wire **135**. A bar **160** is attached to second perpendicular portion **155**. A wire **140** is attached to each side **120** of gate **100**. Wire **140** is approximately parallel to top wire **105**, and is approximately equidistant between top wire **105** and intermediate wire **115**. Wire **140** extends past outer vertical support member **185** and terminates in a connection with the first lateral vertical support member **175** it encounters. Wire **140** creates a hinge for arm **300** to attach to gate **100**. Optionally, wire **140** could extend past the first lateral vertical support member it encounters.

[0032] In the depicted embodiment, top wire **105** of gate **100** measures approximately 414 mm in length. The distance from the end of hooks **110** to second perpendicular portion **155** is approximately 65 mm. The combined length of top wire **105** and hooks **110** is approximately 434 mm. The radius of the bend in hooks **110** is approximately 6 mm. The height from top wire **105** to intermediate wire **115** is approximately 95 mm. The height from intermediate wire **115** to base wire is approximately 188 mm. The left and right sides **120** of gate **100** measure approximately 321 mm in height. The combined length of the attachment members **125** measures approximately 265 mm. The height of each attachment member **125** is approximately 33 mm. The length of each attachment member is approximately 30 mm. The length of base wire **135** is approximately 366 mm. The height from intermediate wire **115** to wires **140** is approximately 55 mm. The height from base wire **135** to highest point is approximately 305 mm. The angle between either side **120** and base wire **135** is approximately 97 degrees. The radius of the bend at the intersection of either side **120** and base wire **135** is approximately 6 mm. The distance between a first end of one bar **160** to a second end of the other bar **160** is approximately 235 mm. The distance between bars **160** is approximately 65 mm. The distance between attachment members is approximately 20 mm. The distance between adjacent lateral vertical support members **175** is approximately 17 mm. The distance between central vertical support members **180** is approximately 20 mm. A person having an ordinary level of skill in the art will understand that the disclosed measurements apply to the depicted embodiment. Differing measurements which approximately preserve the ratios inherent in the disclosed measurements are anticipated by the present disclosure.

[0033] FIGS. 4 and 5 depict base **400**, which comprises seat **405**. Seat **405** includes holes **410**. Holes **410** provide drainage. Ribs **415** on the back of seat **405** provide strength and support. Front divot **420** allows base **400** to fold. Back divot **425** allows a user to grasp and open base **400**. First channel **430** includes stepped portion **440**. Seat **405** also includes inclined portion **445**, which terminates in second channel **435**.

[0034] In the depicted embodiment, seat **405** is approximately 250 mm wide and has a span of approximately 200 mm. The total height of seat **405** from the lowest point to the

top on inclined portion 445 is approximately 38.5 mm. The width of front divot 420 is approximately 59 mm. The height of inclined portion 445 is approximately 19.5 mm. The height of seat 405 at the gate end, where first channel 430 is located, is approximately 22 mm. At its widest point, first channel 430 is approximately 15 mm. The width of stepped portion 440 is approximately 13.8 mm. First channel 430 is approximately 12 mm deep. The opening to first channel 430 is approximately 3 mm wide. The radius of second channel 435 is approximately 7 degrees. The entrance to second channel 435 is approximately 3.3 mm. The distance between the base of first channel 430 and top of seat 405 is approximately 6 mm. Holes 410 are approximately 3 mm tall and 6 mm wide. Holes 410 are approximately 3 mm from the outside of first channel 430. A person having an ordinary level of skill in the art will understand that the disclosed measurements apply to the depicted embodiment. Differing measurements which approximately preserve the ratios inherent in the disclosed measurements are anticipated by the present disclosure.

[0035] Turning next to FIG. 6, arms 300 comprise a first portion 315, a second portion 320, a third portion 325, a fourth portion 330 and a bulbous protrusion 310. The intersection of second portion 320 and fourth portion 330 at one end, and the intersection of bulbous protrusion 310 with fourth portion 330 and third portion 325 at the other create chamber 340. Arm 300 is designed to have the lowest profile when base 400 is closed. Second portion of arm 320 and third portion of arm 325 are angled with respect to one another to allow seat 405 down. Bulbous protrusion 310 allows seat 405 to be flat when open.

[0036] In the depicted embodiment, arms 300 are approximately 278 mm in total length. Arms 300 are angled such that first portion of arm 315 is offset from bulbous protrusion 310 approximately 31 mm. The height from base of coil 305 to the top of bulbous protrusion 310 is approximately 42 mm. The interior diameter of coil 305 is approximately 8 mm. The exterior diameter of coil 305 is approximately 20 mm. The width of coil 305 is approximately 15 mm. The length of first portion of arm 315 including coil 305 is approximately 134 mm. The second portion of arm 320 inclines at an approximate 158 degree angle from first portion of arm 315. Third portion of arm 325 declines at an approximate 31 degree angle from second portion of arm 320. Third portion of arm 325 terminates in bulbous protrusion 310, which extends at a 94 degree angle from third portion of arm 325. Bulbous protrusion 310 includes a first bend 335, which has a 6 degree bend with a radius of approximately 4 mm. The chamber 340 between the intersection of third portion of arm 325 and bulbous protrusion 310 on one side, and the intersection point of bulbous protrusion 310 and fourth portion of arm 330 on the other side is approximately 8 mm. Bulbous protrusion 310 has a length of approximately 37 mm. The distance between the intersections of first portion of arm 315 and second portion of arm 320 and the intersection of second portion of arm 320 and fourth portion of arm 330 is approximately 17 mm. The distance between the intersection of second portion of arm 320 and fourth portion of arm 330 and the base 345 of bulbous portion 310 is approximately 125 mm. The angle between the distal end 350 of coil 305 and third portion of arm 325 is approximately 4 degrees. Bulbous protrusion 310 has a width of approximately 6 mm. A person having an ordinary level of skill in the art will understand that the disclosed measurements apply to the depicted embodiment. Differing

measurements which approximately preserve the ratios inherent in the disclosed measurements are anticipated by the present disclosure.

[0037] FIGS. 7 through 11 depict the interaction of the components of child seat 500. Turning first to FIG. 7, and referencing the other figures accordingly, second channel 435 of seat 405 envelops base wire 210 of back rest 200. Inclined portion 445 gives back rest 200 more elevation without making the back rest component 200 taller. This added elevation from inclined portion 445 allows back rest 200 to remain small enough to fold on top of base 400, and further allow the combination of back rest 200 and base 400 to fold against gate 100. Inclined portion 445 also creates space between base 400 and back rest 200 when these components are folded to accommodate an optional seat belt.

[0038] First portions 315 of arms 300 are welded around wires 140 of gate 100, forming coil 305. This style of welding around wires 140 prevents arms 300 from moving diagonally, thereby creating more stability. This style of welding also avoids a finger trap, wherein a young child's fingers may become stuck and/or injured as a result of placing his or her fingers in between parts of gate 100 and arms 300. The angle at which first portion of arm 315 attaches to gate 100 provides resistance so that a user can belt a child in without gate 100 falling.

[0039] Turning next to FIGS. 12 and 13, when seat 405 is attached to gate 100, attachment members 125 enter into first channel 430. Bar 160 interacts with stepped portion 440 of first channel 430, thereby preventing seat 405 from separating from gate 100. The shape of this locking mechanism allows for the multiple nesting options in the present child seat 500.

[0040] Turning next to FIGS. 14-16, when the child seat 500 is open, as depicted in FIG. 1, bulbous portion 310 of arm 300 encloses first horizontal support member 205 of back rest 200. As child seat 500 moves toward the partially closed position depicted in FIG. 14, wherein back rest 200 lays on top of base 400, first horizontal support member 205 enters chamber 340. The entry of first horizontal support member 205 into chamber 340 allows arms 300 to rotate downward into the position depicted in FIG. 14. When the child seat 500 is partially closed, as depicted in FIG. 14, first horizontal support member 205 rests near the base of chamber 340. As the child seat 500 moves between a partially closed position and a closed position, as depicted in FIG. 15, first horizontal support member 205 again enters chamber 340. When the child seat 500 is fully closed, as depicted in FIG. 16, first horizontal support member 205 rests at the approximate intersection of second portion 320 and third portion 325 of arm 300. The shape of chamber 340 allows first horizontal support member 205 to move easily through chamber 340. Thus, when back rest 200 folds onto base 400, base 400 can fold onto gate 100 with back rest 200 in the middle and not bind.

[0041] Turning to FIGS. 17 and 18, the assembled child seat is depicted in a shopping cart 700. Once assembled, child seat 500 is designed to be installed in either a single basket shopping cart or a two-tier shopping cart. Placing child seat 500 in a two-tier shopping cart, as depicted in FIG. 18, allows a child to sit in the base of the top basket of the cart, creating a lower center of gravity, which in turn provides greater stability. As shown in FIG. 18, when child seat 500 is completely closed, it can be pushed above the shopping cart 700, allowing the upper baskets 710 and lower baskets 720 to nest without interference from child seat 500.

[0042] While the components of child seat **500** have heretofore been described according to exemplary measurements, the size of the components can also be expressed as a ratio. In the depicted embodiment, the height of back rest **200** and the length of seat **400** are approximately equal. In the depicted embodiment, the length of arms **300** is approximately between 1.2 and 1.6 times the height of back rest **200** and length of seat **400**. In the depicted embodiment, the hinge point where arm **300** connects to back rest **200** is approximately between 0.6 and 0.8 times the total height of back rest **200** measured from base wire **210**. The length of the arm **300** is between 75 and 100 percent of the height of gate **100**.

[0043] While a number of exemplary aspects and embodiments have been discussed above, those of skill in the art will recognize certain modifications, permutations, additions and sub-combinations therefore. It is therefore intended that the following appended claims hereinafter introduced are interpreted to include all such modifications, permutations, additions and sub-combinations are within their true spirit and scope. Each apparatus embodiment described herein has numerous equivalents.

[0044] The terms and expressions which have been employed are used as terms of description and not of limitation, and there is no intention in the use of such terms and expressions of excluding any equivalents of the features shown and described or portions thereof, but it is recognized that various modifications are possible within the scope of the invention claimed. Thus, it should be understood that although the present invention has been specifically disclosed by preferred embodiments and optional features, modification and variation of the concepts herein disclosed may be resorted to by those skilled in the art, and that such modifications and variations are considered to be within the scope of this invention as defined by the appended claims. Whenever a range is given in the specification, all intermediate ranges and subranges, as well as all individual values included in the ranges given are intended to be included in the disclosure. When a Markush group or other grouping is used herein, all individual members of the group and all combinations and subcombinations possible of the group are intended to be individually included in the disclosure.

[0045] In general the terms and phrases used herein have their art-recognized meaning, which can be found by reference to standard texts, journal references and contexts known to those skilled in the art. The above definitions are provided to clarify their specific use in the context of the invention.

[0046] All patents and publications mentioned in the specification are indicative of the levels of skill of those skilled in the art to which the invention pertains. All references cited herein are hereby incorporated by reference to the extent that there is no inconsistency with the disclosure of this specification. Some references provided herein are incorporated by reference herein to provide details concerning additional starting materials, additional methods of synthesis, additional methods of analysis and additional uses of the invention.

I claim:

1. A child seat for a shopping cart, comprising:

a gate;  
 a back rest;  
 two arms; and  
 a seat;  
 wherein a first end of said arms connects to said gate;  
 wherein a second end of said arms connects to said back rest;

wherein said seat connects said gate at a first end and said back rest at a second end;  
 wherein said arms attach to said gate at a first elevation when said seat is open;  
 wherein said arms attach to said back rest at a second elevation when said seat is open;  
 wherein said first elevation is greater than said second elevation;  
 wherein the height of said gate is greater than the span of said seat;  
 wherein the height of said gate is greater than the height of said back rest;  
 wherein the second end of said arms terminates in a chamber;  
 wherein said chamber encloses a portion of said back rest;  
 wherein said chamber is shaped to allow said portion of said backrest to move forward, backward, upward and downward.

2. The child seat of claim 1, wherein said seat is attached to said back rest at an angle.

3. The child seat of claim 1, wherein said gate includes attachment members protruding therefrom;

wherein said first end of said seat includes a first channel; and

wherein said first channel envelops said attachment members.

4. The child seat of claim 3, wherein:

each attachment member includes a wire;

said first channel includes a step; wherein

said step interacts with each wire; and

wherein said interaction locks said seat to said gate.

5. The child seat of claim 1, wherein said chamber further comprises:

a first end of a generally straight first portion having a generally ascending direction connected to a first end of a generally straight second portion;

said generally straight second portion having a generally descending direction;

a second end of said generally straight second portion connected to a first end of a bulbous protrusion;

a second end of said bulbous protrusion connected to a first end of a generally straight third portion;

said generally straight third portion terminating at an angle to connect to a second end of said generally straight first portion.

6. The child seat of claim 1, wherein:

said back rest further comprises a base wire;

said second end of said seat comprises a second channel; and

said second channel encompasses said base wire.

7. The child seat of claim 1, wherein:

said back rest further comprises a top wire; and

said top wire further comprises a first divot.

8. The child seat of claim 1, wherein:

said back rest further comprises a first horizontal support member;

said first horizontal support member includes a jog; and

said chamber of said arm attaches to said jog.

9. The child seat of claim 1, wherein:

said back rest further comprises a second horizontal support member; and

said second horizontal support member further comprises a second divot.

10. The child seat of claim 1, wherein said second channel of said seat includes a divot.

11. The child seat of claim 1, wherein the height of said gate is approximately 1.5 times the height of said back rest.

12. The child seat of claim 1, wherein the height of said gate is approximately 1.5 times the span of said seat.

13. The child seat of claim 1, wherein said gate is approximately 283 mm in height and said back rest is approximately 195 mm in height.

14. The child seat of claim 1, wherein said first channel of said seat includes a divot.

15. The child seat of claim 1, wherein said seat further comprises holes.

16. The child seat of claim 1, wherein said seat further comprises ribs.

17. The child seat of claim 1, wherein said first end of said arms is coiled around said gate.

18. The child seat of claim 1, wherein said gate includes at least one opening.

19. The child seat of claim 1, wherein said gate includes hooks for attaching said gate to a shopping cart.

20. The child seat of claim 1, wherein said back rest further comprises a belt.

\* \* \* \* \*