



US 20050270273A1

(19) **United States**

(12) **Patent Application Publication**  
**Marten**

(10) **Pub. No.: US 2005/0270273 A1**

(43) **Pub. Date: Dec. 8, 2005**

(54) **SENSOR FOR CAPACITIVE TOUCH PAD POINTING DEVICE**

**Related U.S. Application Data**

(76) **Inventor: Victor Marten, Flushing, NY (US)**

(60) Provisional application No. 60/320,276, filed on Jun. 13, 2003.

Correspondence Address:  
**OPPEDAHL AND LARSON LLP**  
**P O BOX 5068**  
**DILLON, CO 80435-5068 (US)**

**Publication Classification**

(51) **Int. Cl.<sup>7</sup> ..... G09G 5/00**  
(52) **U.S. Cl. .... 345/173**

(21) **Appl. No.: 10/528,512**

(57) **ABSTRACT**

(22) **PCT Filed: Jun. 10, 2004**

The topology and the shape of sensing electrodes (4, 31) on the Capacity Touch Pad Sensor that allow sensing of small targets are disclosed. Sensor construction utilizes common PCB manufacture technique.

(86) **PCT No.: PCT/IB04/50880**

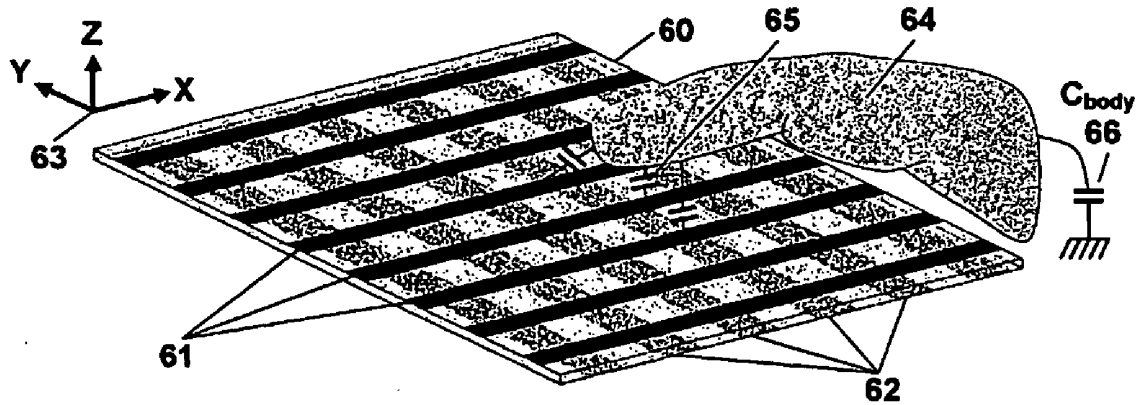

**Conceptual Capacitive Touch Pad Sensor**

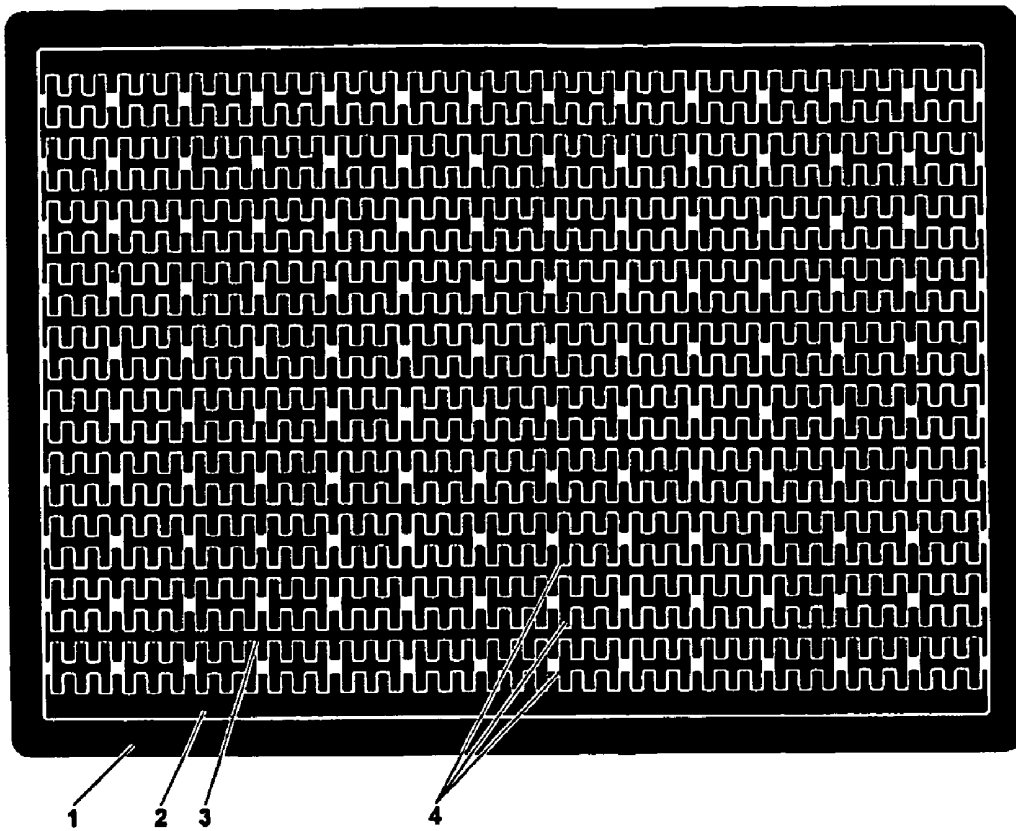

**Figure 1. Artwork for the First (Top) Copper Layer**

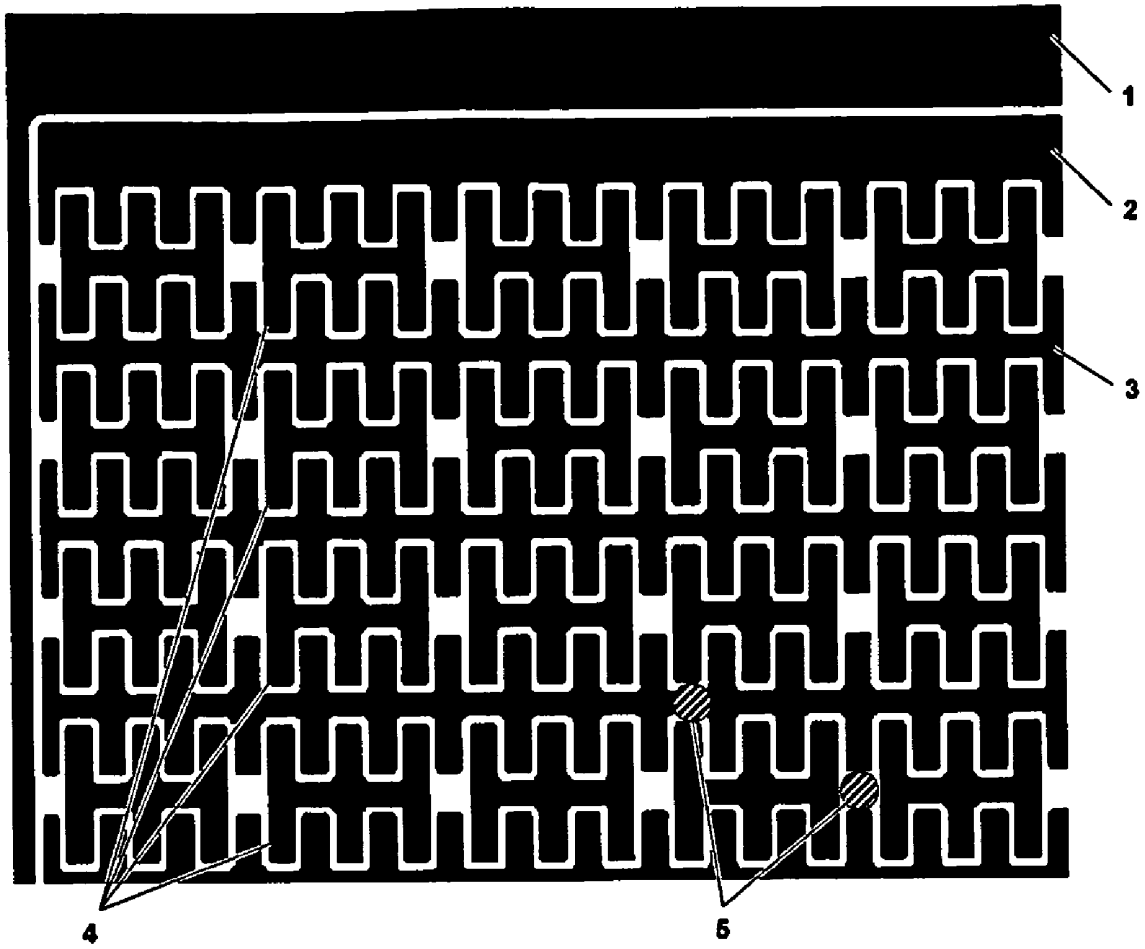

**Figure 2.** Fragment of Magnified Artwork for the First (Top) Copper Layer

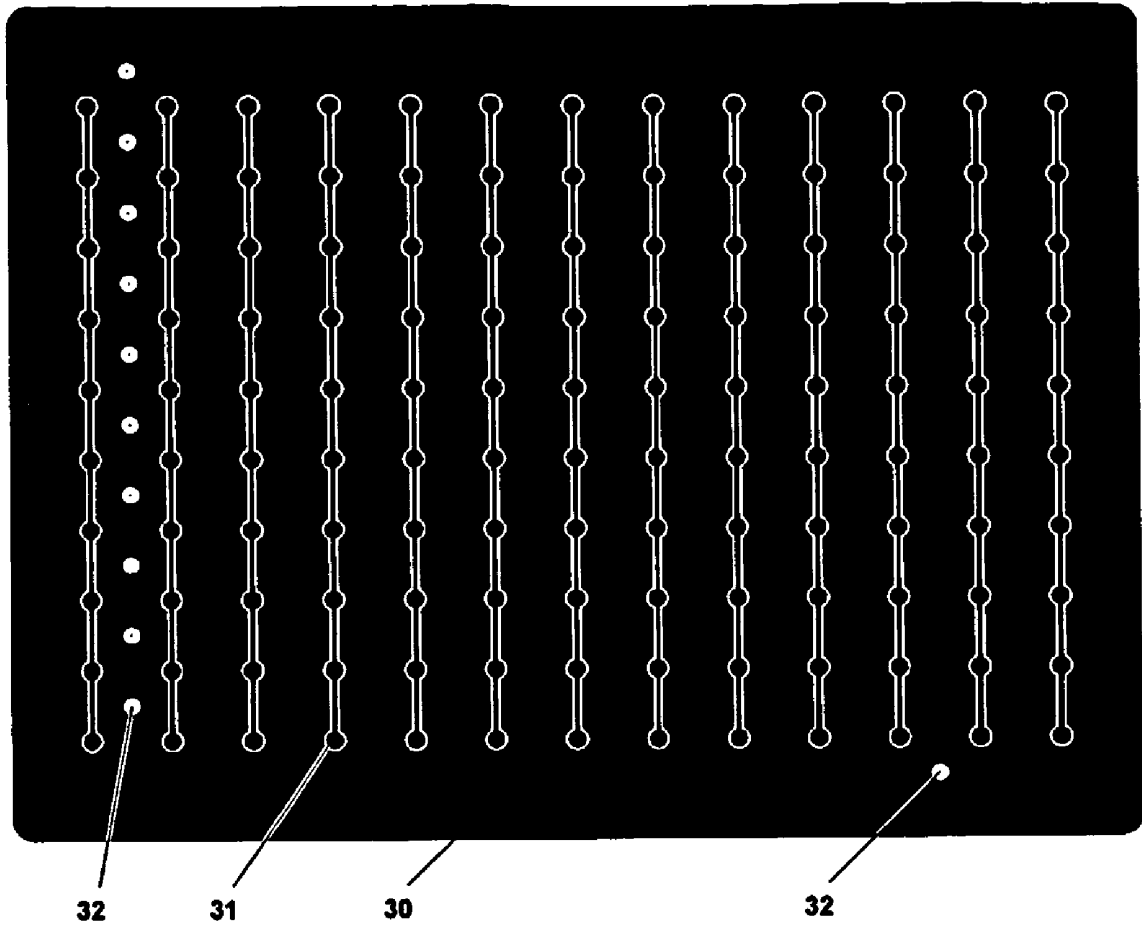

**Figure 3.** Artwork for the Second (Internal) Copper Layer

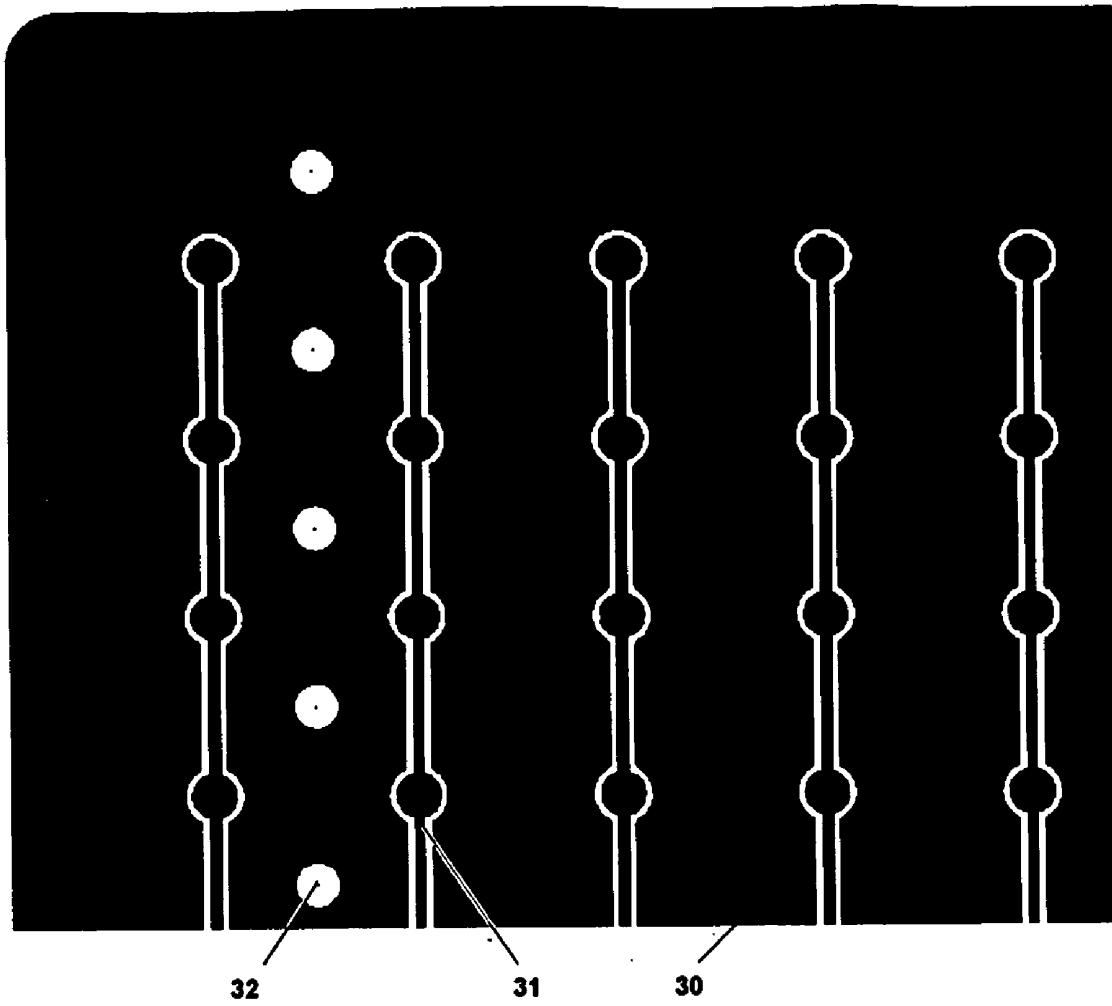

**Figure 4.** Fragment of Magnified Artwork for the Second (Internal) Copper Layer

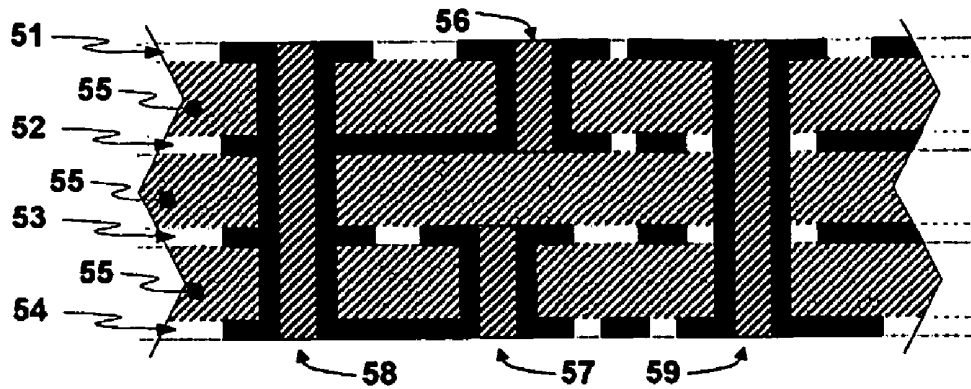

Figure 5. Composition of the PCB for the Capacitive Touch Pad Sensor

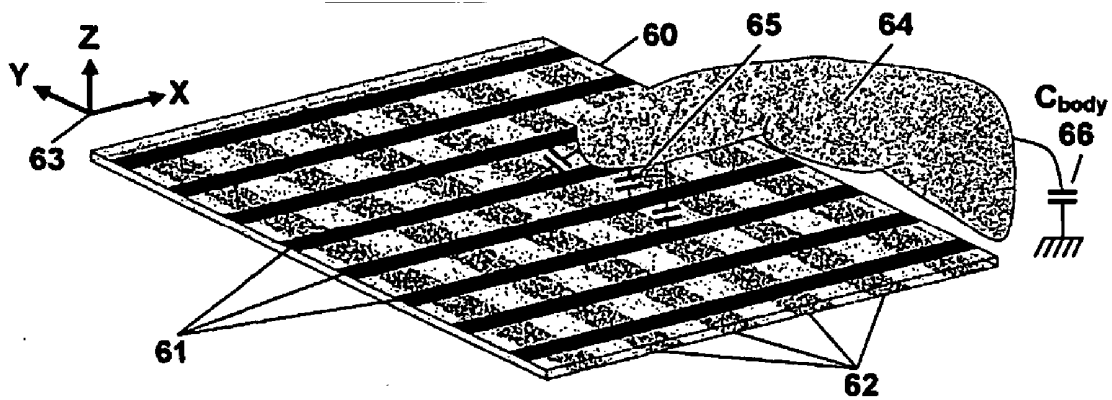

Figure 6. Conceptual Capacitive Touch Pad Sensor

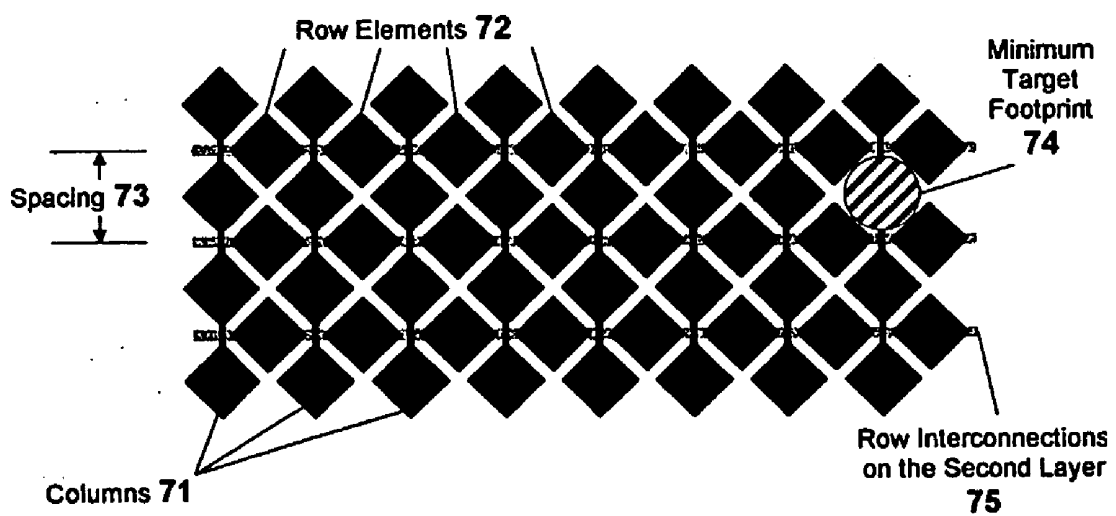

Figure 7. Previous Art

## SENSOR FOR CAPACITIVE TOUCH PAD POINTING DEVICE

[0001] This application claims priority from U.S. appl. No. 60/320,276 filed Jun. 13, 2003, which application is hereby incorporated herein by reference for all purposes.

### BACKGROUND ART

[0002] Modern computing devices typically utilize some form of pointing device for interactions of the user(s) with the Operating System (OS) or Graphical User Interface (GUI). The Capacitive Touch Pad (CTP) is well established as the pointing device of choice for Laptop and Notebook portable computers, and other devices.

[0003] A Conceptual Capacitive Touch Pad **60** is demonstrated in **FIG. 6**. A non-conductive cover that provides galvanic isolation between the user's hand and the Sensor is omitted for clarity here and in **FIGS. 1 through 4**.

[0004] Two groups of electrodes **61** and **62** are utilized. Group **61**, with electrodes parallel to the X-axis, is used for determination of the Y coordinate (according to the system of coordinates depicted as **63**). Group of electrodes **62**, with electrodes parallel to the Y-axis, is used for determination of the X coordinate. When digit **64** is located on or near the surface of the Sensor, the capacitances **65** between the digit **64** and electrodes belonging to group **61** (as illustrated in **FIG. 6**) allow for the determination of the position of the digit **64** in the Y-axis. The capacitances between the digit **64** and group of electrodes **62** (not shown for clarity) allow the determination of the position in the X-axis. It should be noted that the user's body does not need a galvanic contact to ground, and parasitic body capacitance **66** to ground is sufficient for reliable operations, as it is typically several orders of magnitude larger than the capacitances **65**.

[0005] It will be appreciated by a person skilled in the art, that the topology of the electrodes and their exact shape and position will greatly affect the operations of the Capacitive Touch Pad. The capacitances **65** are directly proportional to the area of contact (footprint) between the digit **64** and groups of electrodes **61** and **62**. Therefore, it is desired that the areas of the electrodes on the surface of the Sensor be as great as possible.

[0006] One possible approach utilized in the Prior Art devices is shown in **FIG. 7**. There, the diamond-shaped elements are interconnected into Rows and Columns. The Columns **71** are created by connecting the elements by a trace on the same top layer. The Row elements **72** are joined together by traces **75** on a second layer. The Row element may have galvanic connections, through vias between the layers, or may be capacitively coupled to the traces **75**. The distance between the Rows is illustrated as Spacing **73**.

[0007] It should be self-evident that if a user touches the pad generating a footprint **74** with diameter less than the spacing **73** and positioned as shown, the footprint will not register on the Rows at all.

[0008] In the Prior Art implementations, the ability to sense the small targets is achieved by increasing the number of Rows and Columns. However, this approach necessitates a corresponding increase in the number of signal lines on the sensing and controlling circuit, often implemented as a

single Solid-State Integrated Circuit (IC) or a group of ICs, with corresponding increase in costs.

[0009] It is much more preferable to achieve the objective of small target sensing by some other means, rather than the brute-force approach of employing a simple increase of the number of the sensing electrodes.

### SUMMARY OF INVENTION

[0010] The current invention teaches the topology and shape of sensing electrodes on the Capacitive Touch Pad Sensor that allow sensing of small targets. One specific implementation shown in **FIGS. 1 through 4** provides for a 5x improvement for the size of the minimum footprint necessary for operations of the Capacitive Touch Pad. This implementation uses a common PCB (printed circuit board) manufacturing process without the requirement of super-fine lines and spacings, and without a need for very-small holes and vias.

### BRIEF DESCRIPTION OF DRAWINGS

[0011] **FIG. 1** shows the Artwork for the First (Top) Copper Layer.

[0012] **FIG. 2** depicts a Fragment of the Magnified Artwork for the First (Top) Copper Layer.

[0013] **FIG. 3** shows the Artwork for the Second (Internal) Copper Layer.

[0014] **FIG. 4** demonstrates a Fragment of the Magnified Artwork for the Second (Internal) Copper Layer.

[0015] **FIG. 5** shows the Composition of the PCB for the Capacitive Touch Pad Sensor.

[0016] **FIG. 6** illustrates a Conceptual Capacitive Touch Pad Sensor.

[0017] **FIG. 7** explains Previous Art implementation of a Capacitive Touch Pad Sensor.

### DETAILED DESCRIPTION

[0018] It is desirable for Rows to occupy the whole top area of the Capacitive Touch Pad, with only small isolation gaps between individual Rows, when the measurements of the Y-axis are made; and for the Columns to occupy the whole top area of the Capacitive Touch Pad when the measurements of the X-axis are made. However, it is not practical, since the top area must be shared. The current invention allows for the Rows and Columns to have minimal gaps of coverage as compared to the Prior Art implementations.

[0019] Referring to **FIG. 1** and **FIG. 2**, the Rows **3** are created by utilizing a "double-comb" pattern. It is desirable to have as many "fingers" as possible per unit of length, however the limitations of the manufacturing process impose a bound upon the minimum feature size, both for the copper conductors and for the spaces between them. The Sensor illustrated in **FIGS. 1 through 4** can be produced with a standard low-cost PCB process often called "8/8", meaning that both the minimum well defined copper conductors and the spaces between them are 8 mils (0.008" or 0.2 mm). A person skilled in the art will immediately recognize that if the Capacitive Touch Pad is required to operate with even smaller target footprints, a finer PCB

processing method could be used, resulting in larger number of “fingers” and finer connecting copper traces between them.

[0020] Rows 2, located at the edges of the Sensor, are constructed with the same “comb” pattern on one side, and continuous area on the other side, with the combined total areas of each of the “side” Rows 2 approximately equal to the total areas of every “regular” Row 3.

[0021] Columns are created from individual element 4, which are interconnected via the copper traces 31 on the separate layer (illustrated in FIG. 3 and FIG. 4).

[0022] The “fingers” on the Rows and Columns are interleaved on the Top Layer of the Sensors, allowing for operations with targets having only a small footprint.

[0023] The Sensor includes annular copper 1 around the electrodes, connected to ground potential in normal use. This acts as a shield and a sink for currents created by an Electro-Static Discharge (ESD) event, when the user’s body acquires significant charge, and is discharged when the hand touches the Sensor. A non-conductive cover that provides galvanic isolation between the user’s hand and the Sensor is omitted for clarity in FIGS. 1 through 4. Therefore, the most likely point of entry for the ESD is on the sides of the Sensor, and ESD will be absorbed by the copper 1 and directed to ground without causing any harm to the circuit.

[0024] The Sensor also includes a ground plane 30 on the Second Copper Layer that shields the sensing electrodes on the Top Layer from the circuits typically located on the bottom of the PCB. It is also desirable that the next Layer after the Second Copper Layer incorporates solid areas of copper connected to ground and located under Column traces 31. Using this method all of the sensing electrodes on the Top Copper Layer are electrostatically shielded from the rest of the circuits.

[0025] A ground plane 30 incorporates round areas 32 without copper that are used for vias 59 connecting the Rows 2 and 3 to the rest of the circuit.

[0026] An example composition of the Sensor’s PCB is illustrated in FIG. 5. It shows four (4) separate Copper Layers 51, 52, 53, and 54; inter-layer isolator/dielectric and adhesive 55; and three types of connecting vias 56, 57, and 58. Via 59, although appearing dissimilar, is in fact the same as via 58, except it does not have any connections from the internal Copper Layers 52 and 53. Via 59 is created in the same PCB technological processing step as via 58.

[0027] Layers 51 and 52 are used for the Capacitive Touch Pad Sensor itself, and Layers 53 and 54 are normally used for the circuitry typically located on the bottom of the PCB.

[0028] It will be appreciated by a person skilled in the art that Copper Layer 53 (the next Layer after the Second Copper Layer) is mostly free for wiring except for the grounded areas under traces 31. This allows for easy routing of any circuitry located on the bottom of the PCB.

[0029] It is self evident that the minimum target footprint 5 (FIG. 2) for the current invention is much smaller than the minimum target footprint 74 (FIG. 7) for the Previous Art, under the condition that the spacing between the Rows/Columns for the current invention is the same as the spacing for the Previous Art implementation.

1. A capacitive touch pad comprising first and second layers,

the first layer comprising a non-conductive cover providing galvanic isolation of the second layer,

the second layer comprising a plurality of row-shaped row-sensing electrodes and a row-by-column array of column-sensing electrodes,

each column of column-sensing electrodes interconnected by conductive traces,

the row-sensing electrodes and column-sensing electrodes defining interleaved combs therebetween, each comb comprising at least two fingers.

2. The capacitive touch pad of claim 1 wherein the fingers are no wider than eight mils.

3. The capacitive touch pad of claim 1 wherein the fingers define spaces therebetween, and the spaces are no wider than eight mils.

4. The capacitive touch pad of claim 1 further comprising a third layer, the second layer lying between the first and third layers, the third layer comprising a ground plane.

5. The capacitive touch pad of claim 4 further comprising a fourth layer, the third layer lying between the second and fourth layers, the fourth layer bearing circuitry.

6. The capacitive touch pad of claim 1 wherein in the second layer further comprises annular copper around the electrodes.

7. The capacitive touch pad of claim 6 wherein the annular copper is connected to ground potential.

8. The capacitive touch pad of claim 1 further comprising an isolator/dielectric layer between the first and second layers.

9. The capacitive touch pad of claim 4 further comprising an isolator/dielectric layer between the second and third layers.

10. The capacitive touch pad of claim 5 further comprising an isolator/dielectric layer between the third and fourth layers.

\* \* \* \* \*